

Technical Specification for Communication Equipment

1. TELECOMMUNICATION SYSTEMS	4
1.1 General	4
1.2 Security	4
1.3 SBOM	4
2. FUNCTIONAL REQUIREMENT	5
2.1 Fibre Optic Transmission System	5
2.1.1 General Network Characteristics	5
2.1.2 Features of Transmission Equipment	6
2.1.3 Optical Link Budget Calculations	8
2.1.4 Technical Requirement of Repeater Shelter	9
2.2 Fibre Optic Approach Cable	9
2.3 Optical Fibre Termination and Splicing	10
3. ENVIRONMENTAL, EMI, POWER SUPPLY CABLING AND EARTHING REQUIREMENTS	10
3.1 Environmental Condition	10
4. TESTING	11
5. TRAINING	13
6. SUPPORT SERVICES	13
6.1 Technical Support	14
6.2 Contractor’s Future Hardware/Software Changes	14
6.3 Mandatory Spare Parts	14
6.4 Warranty Period	14
6.5 Miscellaneous Supplies	14
7. DOCUMENTATION	15

Modifications from last revision Rev-05 to Rev-06

- a) SBOM & HBOM: Software Bill of Material (SBOM) and Hardware Bill of Materials (HBOM) has been added as per CERT-In guidelines.
- b) Capacity: STM-64 has been added for future packages requirements of higher capacity requirement.
- c) License: A clause has been added mandating requirement of perpetual license.
- d) IP: IP allocation guidelines have been added to ensure uniformity and compliance.
- e) RBAC access for equipment has been added.
- f) Concreting throughout the floor inside shelter boundary has been provisioned based on site input.
- g) Technical requirement of installation material such as GI pipe, elbow and conduits has been kept in line In line with technical specification of Substation except for nominal bore dia of 32mm instead of 25mm and conformity of specification IS 1239 OR BS 1378.
- h) Type test validity requirement is added as per “Guideline for the Type Tests for Major Equipment in Power Plant” issued by CEA and clause for non-submission of type test report of DG set is kept in line with engineering substation technical specification if DG set make is available in compendium of vendor.
- i) Approval for nomenclature for naming in SDH and its services have been added.

1. TELECOMMUNICATION SYSTEMS

1.1 General

This section describes the Fiber Optic Communication equipment characteristics for communication system to be installed under the project. The sub-systems addressed within this section are:

- (1) Fiber Optic Transmission System (FOTS)
- (2) DDF and Cabling
- (3) Craft Terminal based Network Management System (NMS)
- (4) Repeater Shelter
- (5) FO Approach Cable
- (6) FODP

The equipment supplied shall support existing communication network for Power system operational requirements.

1.2 Security

The security related requirements of the equipment shall be as per CEA (Cyber Security in Power Sector) Guidelines, 2021 and all similar security requirements as amended by CEA on time-to-time basis shall be followed/complied by the vendor at no additional cost to Employer till the implementation of the project.

The manufacturer shall allow the Employer and/or its designated agencies to inspect the hardware, software, design, development, manufacturing, facility and supply chain and subject all software to a security /threat check any time during the supplies of equipment

The contractor shall ensure that the supplied equipment have been got tested as per relevant contemporary Indian or International Security Standards e.g. IT and IT related elements against ISO/IEC 15408 standards, for Information Security Management System against ISO 27001/2, Power Control Systems – Security Requirements against IS 16335, Cyber Security for Industrial Control Systems against IEC 62443-4 etc. from an authorized and certified agency/lab. These mentioned standards shall be current with all amendments, if any and in case any standard is superseded, the new standard shall be applicable.

The Contractor shall ensure that all the Communicable Intelligent Equipment are sourced from the list of the “Trusted Sources” as and when drawn by MoP/CEA. In case, for any Communicable Intelligent Devices, if no Trusted Source has been identified, the Contractor in compliance with the provisions made in MoP order dated 2.07.2020 and any other relevant MoP order shall get the product cyber tested for any kind of embedded malware/Trojan/cyber threat and for adherence to Indian Standards at the designated lab.

In case of any deliberate attempt to make a security breach at the time of procurement or at a later stage after deployment/installation of the equipment or during maintenance, liability may be dealt as per guidelines of CEA/Ministry of Power or any other Government department.

1.3 SBOM& HBOM

The Contractor shall submit the inventory list in line with “Technical Guidelines on

SOFTWARE BILL OF MATERIALS (SBOM) and Hardware Bill of Materials (HBOM)” issued by CERT-In guidelines for approval.

TechnicalGuidelines-on-SBOM,QBOM&CBOM,AIBOM_and_HBOM_ver2.0.pdf

2. FUNCTIONAL REQUIREMENT

The primary function of the equipment is to provide a highly reliable voice and data communication system for grid operation in support of the SCADA/EMS, RTUs & PMUs and for new technological requirements of Power System Operation such as Special Protection Scheme, Grid Security Expert System, Load Management, Advanced Protection System & Substation Automation System. A brief summary of the system requirements is as follows::

- (a) High speed E1 channel support
- (b) 64kbps & nx64kbps data channel support as required
- (c) Low speed (300 -1200 bps) data channel support as required
- (d) Voice (2 wires, 4 wires) channel support and integration with Employer’s/RLDC’s EPABX system. The details of EPABX System shall be provided during detailed engineering.
- (e) Data transport supporting Network Management channels
- (f) The connectivity envisaged between Substation and Control Centre over TCP-IP using Ethernet interface for various services of data and voice such as for PMUs, RTUs, VOIP etc.

2.1 Fibre Optic Transmission System

2.1.1 General Network Characteristics

The SDH node shall be used for interconnection of terminal Substation to the fibre optic network and shall be based on the Synchronous Digital Hierarchy (SDH) having bit rate of STM-4/16/64 as specified in BPS. The contractor shall follow numbering plan for the proposed voice communication system.

The transmission equipment to be supplied shall be a complete SDH node (adddrop multiplexer) providing all the features e.g. protection and performance monitoring. This will be used for delivering E1 as per ITU-T G.703 and Giga/fast Ethernet services except repeater stations. In case other interface such as Asynchronous Subchannel data card (RS232/V.24/V.28), Synchronous data card (V.36/X.21), 2 wire voice channel card or 4 wire (E&M) voice channel card as required, shall be supplied either in the same equipment or as independent PDH equipment.

The Contractor shall supply the equipment as per the technical specification. The deliverables shall include all installation materials necessary for successful installation and commissioning of the equipment viz. AC & DC power supply cabling, Krone type/75Ω BNC type Digital Distribution Frame (DDF) in enclosure, optical patch cords for FODP-to-equipment and equipment-to-equipment connection, optical attenuator (5dB/10dB), flexible conduits etc. as per site requirement. Additionally one (1) pair of optical patch cord per SDH node will be supplied as spare. User Manual, System Guide shall be delivered with each equipment. The Contractor shall provide all required minor civil works necessary for full connectivity as required.

Equipment redundancy and Automatic Protection Schemes (APS) are specified in the next Table. The failure of one element shall not prevent the use of any other that has not failed.

Equipment Redundancy Requirements Summary

<p>Fiber Optic transmission Equipment :</p> <p>Power Supply & Converters ----- ----</p> <p>Common Control* Cards ----- ----</p> <p>* = Common control cards which are essentially required for operation of the equipment.</p>	<p>1:1 APS or distributed power supply</p> <p>1:1 APS</p>
--	---

The offered equipment shall support automatic switchover function between the redundant modules and all required modules and hardware to support the automatic switch over shall be provided by the Contractor.

At any digital signal level, reapplication of a lost signal shall result in automatic resynchronization and full restoration to normal operation without manual intervention. All alarms incident to the signal failure, shall be automatically cleared at the equipment, rack and monitoring levels and normal operation indications restored and reported if applicable.

The offered transmission equipment (SDH node) shall support fibre optic links upto 250 Km for STM-4, upto 225 Km for STM-16 and upto 175 Km for STM-64 without any repeater station in between. If required, wavelength translator/ optical amplifier shall be provided by the contractor.

2.1.2 Features of Transmission Equipment

- Aggregate interface shall be STM-4/16/64, with MSP protected directions (as required in BPS). If bidder is offering equipment with multifunction cards such as cross-connect or control card with optical interface/SFP or tributary interface, such type of multifunction card shall be considered as Common control card and shall be the part of base equipment. In case optical interface/SFP is embedded with control card, the adequate number of optical interface/SFPs shall be offered to meet the redundancy requirements of the specifications. Further, main and protection channel shall be terminated on separate cards. Aggregate interface of STM-4/16/64 shall have FC/PC. In case other than FC-PC connector is provided in the equipment, suitable patch cord with matching connector are to be provided to connect with FODP.
- All software and hardware shall support IPv4 and IPv6 simultaneously (dual stack).
- SDH equipment shall support dual power feed with redundancies for Power supply unit and Control unit in each rack.
- Minimum 16 nos. x 2 Mbit/s per card, 120Ω/75Ω tributary interface compliant to ITU-T G.703, G.704 with suitable connector.
- Ethernet interface shall have minimum 8 nos. per card of RJ-45 port for ingress and egress of Ethernet data (Ethernet over SDH) at 10/100/1000 Base-T speeds/standards (ITU-T G.7041GFP capsulation). Ethernet shall support LCAS feature. It shall support full throughput upto 1000 Mbps on Ethernet port by virtual concatenation of requisite no. of VC-12. There shall be the provision of “Auto Negotiation” and “Flow control” Enabling/disabling through NMS of the system. Also there shall be provision of configuring the equipment for unrestricted nxVC12 bandwidth (upto 1000Mbps). The Ethernet interface shall support VLAN (IEEE 802.IP/Q), spanning tree (IEEE 802.ID) quality of service. The protection scheme for Ethernet traffic should be ERPS based.

- Services channel shall be provided as a function of the SDH equipment and shall be equipped with Service Channel Muldem's that shall provide at a minimum: One voice channel (order wire) with analog interface (0.3 to 3.4 kHz) and one data channel. There shall be a facility to extend the line system order-wire to any other system or exchange lines.
- ADM configuration for traffic protection by using SNCP & MSP.
- Synchronization: The substation GPS can be used for extending synchronization to equipment. Alternately existing network Master Clock can be used for synchronization.
- ISM (In Service Monitoring) circuitry shall be provided as a function of the SDH equipment. Local visual alarm indicators shall be provided on the equipment, as a rack summary alarm panel. Alarms shall be as per ITU-T Standards G.774, G.783 and G.784.
- Downloading of software shall be possible from remote.
- Shall have Embedded Communication Channel (ECC), ports (Ethernet/RS232) for craft terminal and management interface and shall support DCC pass through.
- DCN implementation through protected VC12. Support DCN grooming in VC12.
- Pre-connectorised Optical patch cords shall be of G.625D fibre. The Patch cord return loss shall be equal to or better than 40 dB and insertion loss equal to or less than 0.5 dB. Fiber jumpers shall be of sufficient lengths as to provide at least 0.5m of service loop.
- Manageable by Craft Terminal programme. It shall support performance monitoring, remote software upgrade, configuration management from remote as well as local craft terminal. The craft terminal shall have minimum configuration of 2.4 GHz, 8 GB RAM, 256 MB Video Graphics Memory, 320 GB Hard Disk Drive, keyboard, mouse/trackball etc., serial/USB (2.0) ports to accommodate printers, IEEE 802.11a/b/g wireless LAN, Bluetooth, and a battery back-up of at least 3 hours. VDUs shall be 15" TFT active matrix color LED with a minimum resolution of 1024 X 768.
- Local Craft Terminal will be provided with requisite software for performing all element level management functions viz. configuration management, fault management, performance management etc.
- Shall be operated with -48 V DC Power Supply. DC power interface shall be suitable to work on a nominal voltage of $-48V \pm 20\%$. Compact design suitable for installation in 19" rack.
- The bidder shall be required to provide only Optical Interface/SFP to be installed in the existing/third party SDH equipment at few locations if any. The bidder has to ensure compatibility of the supplied Optical Interface/SFP for the same.
- Licences
All interfaces and features specified in the Technical Specifications of the respective products shall be equipped with perpetual licenses (Not a subscription model).
- IP Address
The Successful Bidder shall be responsible for configuring and assigning IP addresses to all supplied equipment in accordance with the IP addressing scheme provided by the Employer. The Contractor must ensure that all devices are assigned IP addresses as per that scheme, verify connectivity, and document the assigned IPs in the final network configuration report.
- The communication equipment shall support multiple users and access levels at least the following for CLI/NBI access
 - (i) Administrator: Configuration/troubleshooting
 - (ii) Read only access : Only see the equipment status
 - (iii) Operator- Can create configuration but cannot delete

2.1.2.1 Network Monitoring (Craft Terminal based)

- Manageable by Craft Terminal programme. It shall support performance monitoring, remote software upgrade, configuration management from remote as well as local craft terminal. The craft terminal shall have minimum configuration of 2.4 GHz, 8 GB RAM, 256 MB Video Graphics Memory, 320 GB Hard Disk Drive, keyboard, mouse/trackball etc., serial/USB (2.0) ports to accommodate printers, IEEE 802.11a/b/g wireless LAN, Bluetooth, and a battery back-up of at least 3 hours. VDUs shall be 15" TFT active matrix color LED with a minimum resolution of 1024 X 768. However, the configuration shall be finalized during detailed engineering as per the latest industrial standards.
- Local Craft Terminal will be provided with requisite software for performing all element level management functions viz. configuration management, fault management, performance management etc.
- Bidder shall provide the telecom equipment which can be integrated with the existing NMS server/s of the respective RLDC/ SLDC. The details of existing NMS server/s shall be provided during detailed engineering or to be ascertained by Bidder conducted during site survey.

2.1.3 Optical Link Budget Calculations

The fibre optic link budget calculations shall be calculated based upon the following criteria:

- (1) Fibre attenuation: The fibre attenuation shall be taken to be the guaranteed maximum fibre attenuation i.e. 0.21 dB/Km @1550nm and 0.35 dB/km @1310nm.
- (2) Splice loss: Minimum 0.05 dB per splice. One splice shall be considered for every 3 kms.
- (3) Connector losses: Losses due to connectors shall be considered to be minimum 1.0 dB per link.
- (4) Equipment Parameters: The equipment parameters to be considered for link budget calculations shall be the guaranteed "End of Life (EOL)" parameters. In case, the End of Life parameters are not specified for the SDH equipment, an End of Life Margin of at least 2 dB shall be considered and a similar margin shall be considered for optical amplifiers.
- (5) Optical path Penalty: An optical path penalty of at least 1 dB shall be considered to account for total degradations due to reflections, inter symbol interference, mode partition noise and laser chirp.
- (6) Maintenance Margin: A maintenance margin of at least 2.5 dB/100Km shall be kept towards cabling, repair splicing, cable ageing and temperature variations etc.
- (7) Other losses: Other losses, if any required specifically for system to be supplied shall also be suitably considered.
- (8) Dispersion: The fibre dispersion shall be taken to be the guaranteed maximum dispersion i.e. 18 ps/nm.Km @1550 nm & 3.5 ps/nm.km @ 1310 nm for DWDM fibres.
- (9) Bit Error Rate: The link budget calculations shall be done for a BER of 10⁻¹⁰.

The Successful Bidders shall determine the total link loss based on the above parameters

and shall submit the system design (including link budget calculations) for each fibre optic link during detailed engineering.

For finalizing the FOTS system design & BOQ, above methodology shall be adopted taking into account fibre attenuation, dispersion and splice loss determined during the detailed engineering. Accordingly, additions and deletions from the contract shall be carried out based on unit rates indicated in the contract.

2.1.4 Technical Requirement of Repeater Shelter

The detailed requirements for Repeater Shelter are attached at ‘**Annexure – II**’.

2.2 Fibre Optic Approach Cable

For purposes of this specification, a fibre optic approach cable is defined as the Armoured underground fibre optic cable required to connect Overhead Fibre Optic Cable (OPGW) between the final in line splice enclosure on the gantry / tower forming the termination of the fibre cable on the power line and the Fibre Optic Distribution Panel (FODP) installed within the building. The estimated fibre optic approach cabling length requirements are indicated in the appendices. However, the Contractor shall supply & install the optical fibre approach cable as required based on detailed site survey to be carried out by the Contractor during the project execution and the Contract price shall be adjusted accordingly. Approach Cable shall consist G.652D DWDM Fibers.

2.2.1 Basic Construction

The cable shall be suitable for direct burial, laying in trenches, G.I. Pipes PVC/Hume ducts, laying under false flooring and on indoor or outdoor cable raceways.

The Approach Cable shall be a UV resistant, rodent proof, armoured cable with metallic type of armouring. The outer cable jacket for approach cable shall consist of carbon black polyethylene resin to prevent damage from exposure to ultra-violet light, weathering and high levels of pollution. The jacket shall conform to ASTM D1248 for density.

2.2.2 Optical, Electrical and Mechanical Requirements

Approach cable shall contain fibres with identical optical/ physical characteristics as those in the OPGW cables. The cable core shall comprise of tensile strength member(s), fibre support/bedding structure, core wrap/bedding, and an overall impervious jacket.

2.2.3 Installation of Approach Cable

The existing cable trenches/ cable raceways proposed to be used shall be identified in the survey report. The Contractor shall make its best effort to route the cable through the existing available cable trenches. Where suitable existing cable trenches are not available, suitable alternatives shall be provided after Employer approval.

Suitable provisions shall be made by the Contractor to ensure adequate safety earthing and insulated protection for the approach cable.

The required GI pipe (light grade) of suitable size (minimum 32mm), conforming

to IS 1239 or BS 1378, along with required bends, joints, conduit etc. required for laying and installation of approach cable shall be supplied and installed by the Contractor.

2.3 Optical Fibre Termination and Splicing

Optical fibre terminations shall be done in Fibre Optic Distribution Panels (FODP) designed to provide protection for fibre splicing of pre-connectorized pigtailed and to accommodate connectorized termination and coupling of the fibre cables. The Contractor shall provide rack /wall mounted Fibre Optic Distribution Panels (FODPs) sized as indicated in the appendices and shall terminate the fibre optic cabling up to the FODPs. The location of FODP rack shall be fixed by the Contractor, with the Employer's approval.

2.3.1 Fibre Optic Distribution Panel

At each location requiring the termination of at least one fibre pair within a cable, all fibres within that cable shall be connectorized and terminated in Fibre Optic Distribution Panels in a manner consistent with the following:

(a) All fibre optic terminations shall be housed using FODPs provisioned with splice organizers and splice trays. All fibres within a cable shall be fusion spliced to pre-connectorized pigtailed and fitted to the "Back-side" of the provided fibre optic couplings.

(b) FODPs shall be suitable for use with each of the cable types provided as part of this contract. FODPs shall accommodate pass-through splicing and fibre terminations.

(c) FODPs for indoor use shall be supplied in suitable cabinets/racks with locking arrangement.

(d) The FODP shall be of corrosion resistant, robust construction and shall allow both top or bottom entry for access to the splice trays. Ground lugs shall be provided on all FODPs and the Contractor shall ensure that all FODPs are properly grounded. The FODP shall meet or exceed ingress protection class IP55 specifications.

(e) Flexible protection shall be provided to the patch cord bunches going out from FODP cabinet to other equipment cabinet.

3. ENVIRONMENTAL, EMI, POWER SUPPLY CABLING AND EARTHING REQUIREMENTS

3.1 Environmental Condition

Equipment shall operate in accordance with the Environmental Operating limits as shown in the following Table:

Environmental Operating Limits

Temperature Range: Specification Operation without damage Shipping/storage	(Un Controlled Environment) 0 to 45°C -10 to 55°C -40 to 60°C
Relative Humidity, non-condensing	Upto 90%
Elevation: Operating Non-operating	to 3,000 m to 10,000 m

- Equipment shall be properly shielded against radiated emissions at each location.
- Power Distribution and Protection: Power supplies/converters for communications equipment shall use -48Vdc uninterrupted primary source power. The Employer will furnish only one power source. Contractor shall provide required distribution panels, circuit breakers, appropriate panel disconnects and all cabling, fusing, switching required. Distribution Panel feeders, Panel Disconnects, distribution panels and circuit breakers shall be sized and equipped to support at least 100% expanded load requirements. The Contractor shall also be responsible for Load Balancing.
- Contractor shall provide equipment and rack safety earthing in full compliance with EMI/EMC requirements as per relevant international standards.
- Equipment cabinet (enclosure) shall be designed 19 inch, free standing but shall be mounted on the floor. The dimensions of the cabinet shall be minimum 2200mmx600mmx600mm. All doors and removable panels shall be fitted with long life rubber beading. All panels shall be fabricated from minimum 2.0mm thickness steel sheet. However, for racks with load bearing Aluminium extrusion frame, door panels and side panels may be fabricated from minimum 1.6mm thickness steel sheet and the top & bottom panels shall be fabricated from minimum 2.0mm thickness steel sheet. Equipment cabinet (enclosure) shall be dust and moisture proof as per IP41 specification or better (supporting certificates/documents shall be submitted during detailed engineering).
- The Contractor shall provide all required minor civil works necessary for full connectivity as required in the Contractor's scope of work.
- Any other miscellaneous items which may be required for successful interfacing for establishment of end-to-end communication is deemed to be included in the scope of the Contractor.

4. TESTING

All materials furnished and all work performed under this Contract shall be inspected and tested. The entire cost of testing for factory & site acceptance, routine tests, production tests and other test during manufacture & site activities specified herein shall be treated as included in the quoted unit price of materials, except for the expenses of Inspector/Employer's representative.

Type tests shall not be required to be carried out if supplier has conducted these tests earlier on the same type of equipment and valid type test certificates are available. The

test certificate shall be considered valid if,

- i. Tests conducted earlier is either conducted in accredited laboratory (accredited based on ISO/IEC 17025 by the National Accreditation body of the country where laboratory is located) or witnessed by POWERGRID/representative authorized by POWERGRID/representative of Utility /representative of accredited test lab/ representative of The National Accreditation Board for Certification Bodies (NABCB) certified agency.
- ii. Type test reports contain valid Calibration reports/certificates of the relevant testing equipment, information pertaining to ratings, the relevant drawings, model number, test circuit, calculations (if any), photos, acceptance criteria/values specified in Technical Specification/ relevant standards (IS/ IEC) and compliance to the same.
And
- iii. The Equipment shall be supplied from the same manufacturing works, where from the sample was manufactured and successfully type tested as per relevant standard or at the works of Parent organization in case of technology transfer/ Joint Venture (JV) for the initial period of 03 years from the date of establishment of manufacturing plant for offered equipment provided that the design, material, and manufacturing process of the offered equipment are identical to those of the type-tested sample of the original facility. In such cases, while submitting the Type Test Reports, the Original Equipment Manufacturer (OEM), shall furnish an undertaking with it declaring that there is
 - a) No change in the Design,
 - b) No change in the material,
 - c) No change in manufacturing process, and
 - d) No amendment/revision in the relevant standard as regard to type test conditions, since the type test
- iv. In case of own manufacturing plant at different location within India, the type test of the original manufacturing works shall also be acceptable for the equipment manufactured and supplied from the different location subject to the following conditions:
 - a. the relevant standard does not bar the same,
 - b. the equipment being manufactured at different locations shall be identical in design, drawings, specifications, ratings to that of the type tested sample in the original facility (where it was manufactured and successfully type tested),
 - c. the equipment being manufactured at different locations shall be identical in material & critical components, manufacturing process/ practices, and quality control to that of the type tested sample in the original facility (where it was manufactured and successfully type tested),
 - d. Also, while submitting the Type Test Reports, the Original Equipment Manufacturer (OEM), shall furnish an undertaking for above conditions (a), (b) and (c).

"Type Tests" shall be defined as those tests which are to be carried out to prove the design, process of manufacture and general conformity of the materials to this Specification. All equipment being supplied shall conform to type tests as per Annexure-I of technical specification. The test reports submitted shall be of the tests conducted with validity period as per Guideline for the Type Tests for Major Equipments in Power Plant. Type test validity and other requirement for type testing shall be governed from the "Guideline for the Type Tests for Major Equipments in Power Plant".

Link as below

["Final Type Test Guidelines 2026.pdf"](#)

Major item's type test validity is as below.

S.No.	Name of Equipment	Validity of type test
-------	-------------------	-----------------------

		(in years) from originally scheduled last date of bid submission
1	SDH Equipment	10
2	Fiber Optic cable(Approach Cable)	10
3	Cable (Power, Control)	10
4	Battery, Battery charger	10
5	DG set	10

The type test report for DG Set comprising of diesel engine and alternator are not required to be submitted for the makes listed in Compendium of Vendors of POWERGRID. For the new makes, type test reports of engine and alternator as per relevant standard shall be submitted for purchaser's approval.

In case the test reports are older than the duration specified, the Contractor shall repeat these tests at no extra cost to the purchaser. In the event of any discrepancy in the test reports or any type tests not carried out, same shall be carried out by Contractor without any additional cost implication to the Employer. Type Tests shall be certified or performed by reputed laboratories using material and equipment data sheets and test procedures that have been approved by the Employer.

Equipment to be delivered shall be tested at factory before dispatch as per approved procedure. Factory Acceptance Test shall demonstrate the technical characteristics of the equipment in relation to this specification and approved drawings and documents. The Contractor shall provide procedures for installation and site acceptance test. The site acceptance testing will comprise of end- to-end testing between the terminal stations and RLDC/SLDC and RTAMC/other CC end.

The detailed requirements for Type Test, Factory Acceptance Test and Site Acceptance Test are attached at '**Annexure – I**'.

Standard Procedure for Type test, Factory acceptance test and Site acceptance test are attached at '**Annexure-I (A)**' (Test shall be applicable as per offered items)

5. TRAINING

The Contractor will provide a training of suitable duration on supplied SDH equipment for Employer's personnel to provide working knowledge of the equipment, operation and diagnostic tools, supervision and monitoring using local craft terminal. The training may be provided by the Contractor or its sub-vendor at the site itself, preferably prior to installation, and will include training materials, presentation equipment, and all associated expenses.

No separate charges for training shall be payable to the Contractor.

6. SUPPORT SERVICES

Throughout design, implementation, factory testing, and field installation and testing, the Contractor shall supply consulting assistance, as required by the Employer for site preparation, field installation, and other areas where technical support may be required.

The Contractor shall be responsible for minor facility renovation, and maintenance of

the supplied system up to and including successful completion of the Site Acceptance Test.

After final acceptance of the communications equipment, the Contractor shall offer continuing technical support and spare parts for the communication equipment for a minimum period of 15 years from operational acceptance by the employer or 7 years after the declaration of withdrawal of equipment from production whichever is earlier. However, the termination of production shall not occur prior to Operational Acceptance of the system by the Employer. Some locations have existing SDH & MUX equipment. The traffic may be switched over to new fibre optic communication equipment in phase manner. The Contractor shall review the Employer existing equipment make, integration & switch over recommendation and prepare a detailed field implementation plan.

6.1 Technical Support

Consultation with Contractor's technical support personnel and trained field service personnel shall be readily available on a short-term/long-term basis to assist the Employer personnel in maintaining, expanding, and enhancing the telecommunication network upon expiration of the warranty period.

6.2 Contractor's Future Hardware/Software Changes

The Employer shall be informed of all alterations or improvements to the hardware supplied under this Specification. The Employer shall be placed on the Contractor's mailing list to receive announcements of the discovery, documentation, and solution of hardware/software problems as well as other improvements that could be made to supplied equipment. The service shall begin at the time of contract award, and shall continue for a minimum period of 15 years from operational acceptance by the employer or 7 years after the declaration of withdrawal of equipment from production whichever is earlier. The Contractor shall also include a subscription to the hardware subcontractors' change notification service from the time of contract award through the warranty period, with an Employer renewable option for extended periods.

6.3 Mandatory Spare Parts

The Contractor shall be required to supply minimum spares for each subsystem as in BPS. The subsystem set of spare parts is defined to include all equipment modules, subunits and parts required to effect replacement, repair and restoration to full operational status of a defined unit of a subsystem (i.e. SDH equipment).

6.4 Warranty Period

The one-year period commencing immediately after the operational acceptance is called the Warranty Period/Defect liability Period. In addition to the responsibilities covered under Vol-I Condition of Contracts during Defect Liability Period, the Contractor shall also be responsible for maintenance of the Fibre Optic Transmission System etc. supplied under this Package.

6.5 Miscellaneous Supplies

The Contractor shall provide all required consumable and non-consumable supplies necessary to support all installation and test activities through final operational

acceptance. However, if there are any problems in the SAT and additional consumables are required, the same shall also be supplied by the Contractor at no additional cost.

7. DOCUMENTATION

The Contractor shall submit following documents during detailed engineering:

- (a) Data Requirement sheets
- (b) Link Budget calculations
- (c) MQP, FQP, if applicable
- (d) Bill of Quantity including mandatory spares
- (e) Previous Type test reports
- (f) Factory Test report
- (g) Manuals for each equipment
- (h) Schematic drawing
- (i) Numbering, Marking, labelling documents
- (j) Synchronization plan
- (k) Test schedule
- (l) Training manual
- (m) Configuration diagram
- (n) Transportation & handling Procedure
- (o) Installation Manuals
- (p) Maintenance Manual
- (q) Nomenclature: The contractor is responsible to follow standard naming in SDH and its services. Same shall be finalized during detailed engineering.

Testing Requirement of Communication Equipment

1.1 List of type test to be conducted on Telecom equipment

The type tests for Telecom Equipment with all types of cards are described below:

1.1.1 Temperature and Humidity Tests

The tests listed below are defined in IEC Publication 60068.

(a) Low Temperature Test: Operation to Specifications

Low temperature tests shall be conducted as defined in IEC Publication 60068-2-1, test method Ad, with the following specifications:

- (1) Test Duration: The equipment is started up as soon as thermal equilibrium has been reached and operated for sixteen (16) hours. Its performance is checked during the test.
- (2) Degree of Severity: Test shall be done at 0°C
- (3) Acceptance Criteria: No degradation of performance during and after the test.

(b) Low Temperature Test : Operation without Damage

Low temperature tests shall be conducted as defined in IEC Publication 60068-2-1, test method Ad, with the following specifications:

- (1) Test Duration: The equipment is started up as soon as thermal equilibrium has been reached and operated for 72 hours. Its performance is checked during the test and after the test as soon as the thermal equilibrium is reached at the room temperature (*Post-test*).
- (2) Degree of Severity: Test shall be done at -10° C
- (3) Acceptance Criteria: Degradation of performance is allowable during the test, however there shall be no degradation of performance in the *post-test*.

(c) Dry Heat Test: Operation to Specifications

Dry heat test shall be done as defined in IEC Publication 60068-2-2, test method Bd, with the following specifications:

- (1) Test Duration: The equipment is started up as soon as thermal equilibrium has been reached and operated for 96 hours. Its performance is checked during the test.
- (2) Degree of Severity: operation to specification range.
- (3) Acceptance Criteria: No degradation of performance during and after the test.

(d) Dry Heat Test: Operation without Damage

Dry heat tests shall be done as defined in IEC Publication 60068-2-2, test method Bd, with the following specifications:

- (1) Test Duration: The equipment is started up as soon as thermal equilibrium has been reached and operated for 96 hours. Its performance is checked during the test and after the test as soon as the thermal equilibrium is reached at the room temperature (*Post-test*).
- (2) Degree of Severity: Test shall be done at 55°C.
- (3) Acceptance Criteria: Degradation of performance is allowable during the test, however there shall be no degradation of performance in the *post-test*.

(e) Damp Heat Test

Damp heat testing reveals aging with respect to the humidity level and applies basically to electronic equipment. This test shall be done as defined in IEC Publication 60068-2-3 with the following specifications:

- (1) Test Duration: The equipment is started up as soon as thermal equilibrium has been reached and operated for 10 days. Its performance is checked during the test.
- (2) Degree of Severity: Test shall be done at $(40 \pm 2) ^\circ\text{C}$ & $(93 \pm 3) \% \text{RH}$
- (3) Acceptance Criteria: The equipment shall meet the specified requirement and there shall not be any degradation in BER.

(f) Temperature Variation Test

Temperature variation testing shall be as per IEC Publication 60068-2-14 (Gradual Variations, Method Nb). The equipment shall be powered on and various parameters shall be monitored continuously during the test period.

- (1) Number of cycles required is five (5)
- (2) The degree of severity: temperature TL:0°C, TH: (Operation to specification range)
- (3) Cycle duration for each temperature is three (3) hours.
- (4) Ramp : 1 °C/minute.
- (5) Acceptance Criteria: The equipment shall meet the specified requirement and there shall not be any degradation in BER.

1.1.2 Power Supply and EMI/EMC tests

The test procedure and acceptance criteria shall be as defined in IEC 60870-2-1.

(a) Immunity Tests

The list of Immunity tests are specified below in Table 1:

Table 1: Recommended Immunity Tests

S. No.	Immunity Test	AC Power Supply	DC Power Supply	Control & Signal	Telecom Line	Parameters
1	Voltage Fluctuations	Yes	Yes	N/A	N/A	Table 11 of IEC 60870-2-1: 1995 - Level : 1
2	Voltage dips and Interruptions	Yes	Yes	N/A	N/A	
3	1.2/50 - 8/20 μ s surges	Yes	Yes	Yes	N/A	Table 12 of IEC 60870-2-1: 1995 - Level : 1
4	Fast transient bursts	Yes	Yes	Yes	Yes	Table 12 of IEC 60870-2-1: 1995 - Level : 4
5	Damped oscillatory waves	Yes	Yes	Yes	Yes	Table 12 of IEC 60870-2-1: 1995 - Level : 1
6	Electrostatic discharge	Yes				Table 13 of IEC 60870-2-1: 1995 - Level : 4
7	Radiated electromagnetic field	Yes				Table 15 of IEC 60870-2-1: 1995 - Level : 4
-End of Table-						

(b) Emission Tests

The list of Emission tests are specified below in Table 2

Table 2: Recommended Emission Tests

S. NO.	Emission test	AC Power Supply	DC Power Supply	Control & Signal	Telecom Line	Parameters
1	RF disturbance voltages CISPR 22	Yes	Yes	N/A	N/A	Table 17 of IEC 60870-2-1: 1995 - Class : B
2	RF disturbance currents CISPR 22	N/A	N/A	N/A	Yes	
3	RF radiated fields CISPR 22	Yes				
-End Of Table-						

(c) Insulation Withstand Voltages

As per section 6 of IEC 870-2-1. Recommended class: VW1 of Table 18.

1.1.3 Mechanical Tests

(a) Mechanical Vibration Test

The procedure for this test is described in IEC Publication 60068-2-6. The testing procedure shall be carried out in the sequence 8.1 + 8.2.1 + 8.1 as described in document 60068-2-6. For the vibration response investigation (clause 8.1 of 60068-2-6), the test shall be carried out over a sweep cycle under the same conditions as for the endurance test (described later), but the vibration amplitude and the sweep rate may be decreased below these conditions so that the determination of the response characteristics can be obtained.

The endurance tests conditions are selected according to the vibration withstand requirements.

Transportation tests shall be performed with the equipment packed according to the Contractor's specifications.

(b) Shock Test

The procedure of this test is defined in IEC Publication 60068-2-27 (each test) with a semi-sinusoidal shape (clause 3.1.1.2).

The recommended severity shall be $A = 294 \text{ m/s}^2$, $D = 18 \text{ ms}$. Three shocks per axis per direction shall be applied to the equipment packed according to the Contractor's specifications.

Or Free Fall Test

This test could be performed as an alternative to the shock or Bump test. The procedure is defined in IEC publication 60068-2-32. The equipment shall be packed according to the Contractor's specifications. The drop height shall be defined in accordance with IEC 68-2-32. The surface of the packing case which comes into contact with the ground is the surface on which the packing case normally rests; if the packing does not have any features (inscription, special shape, etc.) identifying this surface, the test is carried out successively on all the surfaces of the packing.

Or Bump Test

This test could be performed as an alternative to Shock test or Free Fall test. The procedure is defined in IEC 60068-2-29.

1.2 Type tests for Optical Fibres

The type tests listed below in Table 3 shall be conducted on DWDM fibres to be supplied as part of Approach cable. The tests specific to the cable type are listed in subsequent sections.

**Table 3
Type Tests For Optical Fibres**

S. No.	Test Name	Acceptance Criteria	Test procedure
1	Attenuation	As per Standard	IEC 60793-1-40 Or EIA/TIA 455-78A
2	Attenuation Variation with Wavelength	As per Standard	IEC 60793-1-40 Or EIA/TIA 455-78A
3	Attenuation at Water Peak	As per Standard	IEC 60793-1-40 Or EIA/TIA 455-78A
4	Temp. Cycling (Temp dependence of Attenuation)		IEC 60793-1-52 Or EIA/TIA 455-3A, 2 cycles
5	Attenuation With Bending (Bend Performance)		IEC 60793-1-47 Or EIA/TIA 455-62A
6	Mode Field dia.		IEC 60793-1-45 Or EIA/TIA 455-164A/167A/174
7	Chromatic Dispersion		IEC 60793-1-42 Or EIA/TIA 455-168A/169A/175A
8	Cladding Diameter		IEC 60793-1-20 Or EIA/TIA 455-176
9	Point Discontinuities of attenuation		IEC 60793-1-40 Or EIA/TIA 455-59
10	Core -Clad concentricity error		IEC 60793-1-20 Or EIA/TIA 455-176
11	Fibre Tensile Proof Testing		IEC 60793-1-30 Or EIA/TIA 455-31B
-End Of table-			

1.3 Type tests for Fibre Optic Approach Cable

The type tests to be conducted on the Fibre Optic Approach cable are listed in Table 4: Type Tests for Fibre Optic Approach Cable. Unless specified otherwise in the technical specifications or the referenced standards, the optical attenuation of the specimen, measured during or after the test as applicable, shall not increase by more than 0.05 dB/Km.

**Table 4:
Type Tests Fibre Optic Approach Cable**

S.NO.	Test Name	Test Procedure
1	Water Ingress Test	(IEC 60794-1-F5 / EIA 455-82B) Test duration : 24 hours
2	Seepage of filling compound	(EIA 455-81A) Preconditioning : 72 hours, Test duration : 24 hours.
3	Crush Test	(IEC 60794-1-E3/ EIA 455-41)
4	Impact Test	(IEC-60794-1-E4/ EIA 455-25A)
5	Stress strain Test	(EIA 455-33A)
6	Cable Cut-off wavelength Test	(EIA 455-170)
7	Temperature Cycling Test	(IEC60794-1-F1/EIA-455-3A) – 2 cycles
-End Of Table-		

1.4 Factory Acceptance Test Requirement

Factory acceptance tests shall be conducted on randomly selected final assemblies of all equipment to be supplied. Factory acceptance testing shall be carried out on Approach Cable, FODP, Craft terminal, SDH Equipments, associated line & tributary cards, and all other items for which price has been identified separately in the Bid Price Schedules.

Material shall not be shipped to the Employer until required factory tests are completed satisfactorily, all variances are resolved, full test documentation has been delivered to the Employer, and the Employer has issued CIP Clearance/Interim Inspection Report. Successful completion of the factory tests and the Employer approval to ship, shall in no way constitute final acceptance of the system or any portion thereof. These tests shall be carried out in the presence of the Employer's authorised representatives unless waiver for witnessing by Employer's representatives is intimated to the contractor.

Factory acceptance tests shall not proceed without the prior delivery to and approval of all test documentation by the Employer.

The factory acceptance test shall demonstrate the technical characteristics of the equipment in relation to this specifications and approved drawings and documents. List of factory acceptance tests for Fibre Optic Transmission system, Approach cable, Craft terminal, and FODP are given in specified Tables in this section. This list of factory acceptance tests shall be supplemented by the Contractor's standard FAT testing program. The factory acceptance tests for the other items shall be proposed by the Contractor in accordance with technical specifications and Contractor's (including Sub-Contractor's / supplier's) standard FAT testing

program. In general the FAT for other items shall include at least: Physical verification, demonstration of technical characteristics, various operational modes, functional interfaces, alarms and diagnostics etc.

During FAT stage, the employer has to verify all type test reports/certificates including Communication Protocol and security conformance tests of the devices offered for FAT as part of essential cyber security tests. The equipment/system besides for functionality shall also be tested in the factory for vulnerabilities, design flaws, parts being counterfeit or tainted, so as to minimize problems during on-site testing and installation. Cyber security conformance testing are to be carried out in the designated lab as identified by GoI/MoP.

The following auditor report and audit recommendations are to be verified during FAT.

1. Vulnerability assessment
2. Risk assessment
 - a. Network architecture validation with respect to design documents.
 - b. Penetration testing
 - c. System Hardening test

1.4.1 Sampling for FAT

From each batch of equipment presented by the Contractor for Factory acceptance testing, the Employer shall select random sample(s) to be tested for acceptance. Unless otherwise agreed, all required FAT tests in the approved FAT procedures, shall be performed on all samples. The Sampling rate for the Factory acceptance tests shall be minimum 10% of the batch size (minimum 1) for all items. The physical verification shall be carried out on 100% of the offered quantities as per the approved FAT procedure. In case any of the selected samples fail, the failed sample is rejected and additional 20% samples shall be selected randomly and tested. In case any sample from the additional 20% also fails the entire batch may be rejected. In case a number of equipments are required for demonstration of the performance of any equipment during FAT, the sample size shall be taken as that number of equipments which are necessary to demonstrate the performance, irrespective of the percentage.

The Sampling rate for the Factory acceptance tests shall be 10% of the batch size (minimum 2) for FO cable drums, FODPs, and other similar items.

Since FAT testing provides a measure of assurance that the Quality Control objectives are being met during all phases of production, the Employer reserves the right to require the Contractor to investigate and report on the cause of FAT failures and to suspend further testing/ approvals until such a report is made and remedial actions taken, as applicable.

1.4.2 Production Testing

Production testing shall mean those tests which are to be carried out during the process of production by the Contractor to ensure the desired quality of end product to be supplied by him. The production tests to be carried out at each stage of production shall be based on the Contractor's standard quality assurance procedures. The production tests to be carried out shall be listed in the Manufacturing Quality Plan (MQP), alongwith information such as sampling frequency, applicable standards, acceptance criteria etc.

The production tests would normally not be witnessed by the Employer. However, the Employer reserves the right to do so or inspect the production testing records in accordance with Inspection rights specified for this contract.

**Table 5:
Factory Acceptance Testing for Fibre Optic Transmission System**

Item:	Description:
1.	Physical inspection for conformance to DRS, BOQ, drawings and appearance of equipment
2.	Optical output power
3.	Transmitter lightwave spectral analysis
4.	Low receive level threshold
5.	Generation of bit error rate curve
6.	Measurement of analog and digital service channel parameters as well as service channel functionality
7.	Performance of supervision, alarm, Craftsperson interface, diagnostics, loop backs etc.
8.	Electrical interface tests which include: output and input jitter, bit error rate, pulse shape, cable compensation, and line rate tolerance for multiplexers
9.	At a minimum tests on Ethernet interface shall include demonstration of ping test, throughput test, Latency test, Packet Loss test as per RFC 2544
11.	Simulation of failure conditions and failover of each redundant unit.
12.	VLAN (Layer-2 switching) feature testing configuration.
13.	Protection scheme for Ethernet Traffic (ERPS)
14.	Test of spare card slots
15.	Checks of power supply/converter voltage margins

**Table 5:
Factory Acceptance Testing for Fibre Optic Transmission System**

16.	Random inspections to verify the accuracy of documentation
17.	Test of spare parts/modules/cards as per applicable tests
18.	Comprehensive Cyber Security Tests in compliance to latest cyber security guidelines issued by CEA/MoP or any other govt department.

**Table 6
FAT on NMS (Craft Terminal)**

1	Physical inspection of NMS hardware (Craft Terminal) for conformance to approved BoQ, DRS & drawing
2	Testing of NMS to demonstrate proper operation of all functions: Configuration Management, Performance Management, Fault Management and Security Management.

**Table 7
Factory Acceptance Tests On Approach Cable**

Factory Acceptance Test	
Attenuation Co-efficient at 1310 nm and 1550 nm	
Point discontinuities of attenuation	
Visual Material verification and dimensional checks as per approved DRS/Drawings	

**Table 8
Factory Acceptance Test**

Visual check of Quantities and Specific Component Number for each component of FODP and dimensional checks against the approved drawings.	
---	--

1.5 Site Acceptance Tests

All equipment shall be tested on site under the conditions in which it will normally operate.

The tests shall be exhaustive and shall demonstrate that the overall performance of the contract works satisfies every requirement specified. At a minimum Site Acceptance Testing requirement for Telecom equipment, NMS etc. is outlined in following section. This testing shall be supplemented by the Contractor's standard installation testing program, which shall be in accordance with his quality plan(s) for Telecom equipment installation.

During the course of installation, the Employer shall have full access for inspection and verification of the progress of the work and for checking workmanship and accuracy, as may be required. On completion of the work prior to commissioning, all equipment shall be tested to the satisfaction of the Employer to demonstrate that it is entirely suitable for commercial operation.

1.5.1 Phases for Site Acceptance Testing

The SAT shall be completed in following phases:

1.5.1.1 Installation Testing

The field installation test shall be performed for all equipment at each location. If any equipment has been damaged or for any reason does not comply with this Specification, the Contractor shall provide and install replacement parts at its own cost and expense.

In the installation test report, the Contractor shall include a list of all hardware or components replaced or changed between the completion of factory tests and the start of field tests and show that documentation and spare parts have been updated.

During Installation testing, the employer has to verify all type test reports/certificates including Communication Protocol and security conformance tests of the devices as part of essential cyber security tests.

The following auditor report and audit recommendations are to be verified during SAT.

1. Vulnerability assessment
2. Risk assessment
 - a. Network architecture validation with respect to design documents.
 - b. Penetration testing
 - c. System Hardening test

The minimal installation testing requirements for fiber optic transmission subsystem are provided in the table below:

Table 9
Fibre Optic Transmission system Installation Testing

Item:	Description:
1.	Physical Inspection for conformance to drawings, rack elevations and appearance of equipment and cabling
2.	Equipment power supply (DC-DC converter) output voltage measurements
3.	Terminal transceiver performance testing (Tx power, Tx spectrum, receive signal strength, connector losses etc.)
4.	Service channel performance
5.	Craftsperson interface, alarm and control functional performance
6.	Rack and local alarms: No alarms shall be present and all alarms shall be demonstrated to be functional
7.	Network management interface and supervision performance
8.	Correct configuration, level setting & adjustments and termination of Input/output interfaces
9.	Proper establishment of Safety and signalling earthing system and resistance to ground to be checked.
10.	Simulation of failure conditions and failover of protected components.
11.	Comprehensive Cyber Security Tests in compliance to latest cyber security guidelines issued by CEA/MoP or any other govt department.

1.5.1.2 Link Commissioning Tests

The commissioning tests shall verify that communication can be performed over the fiber optic link under test. Delay measurement, Bit Error measurements & service channel performance monitoring shall be made on the fibre optic links to verify compliance with designed link performance.

For Ethernet interface: At a minimum the following test requirements shall be demonstrated as per RFC 2544:

- a) Ping test
- b) Throughput test
- c) Latency test
- d) Packet Loss

The links shall be tested for 12 Hour. In case any link does not meet the performance requirements during 12 hour, then the cause of failure shall be investigated and the test shall be repeated after rectifying the defects.

This phase of testing shall be conducted by the Contractor and witnessed by the Employer. Field adjustments shall be made to meet established standard, however if the field adjustments fail to correct the defects the equipments may be returned to the Contractor for replacement at his own expense. In case any adjustments are required to be made during the interval of the test then the test shall be repeated.

1.5.1.3 Integrated Testing

Prior to commencement of integrated testing the overall system shall be configured as required to provide all the data and voice channel required to interconnect to control centres and other nodes in existing system. The integrated testing shall include end-to-end testing of communication.. The intent of integrated testing is to demonstrate that the equipment is operational end to end under actual conditions, that all variances identified during factory and field installation and communications testing have been corrected, and that the communication equipment is compatible with other equipment. The Integrated System Test shall include all fibre optic transmission equipment, the network management subsystem (Craft Terminal) and other components.

At a minimum the following tests shall be included in the integrated testing:

- (1) Equipment configuration shall be checked to establish that it supports the channel routing.
- (2) End to end testing of all individual voice circuits (VOIP) and to demonstrate proper operation of channels over wideband systems. Operation shall be checked in terms of quality of voice, call initiation and call termination processes.
- (3) End-to-end testing of all individual Data Circuits (Ethernet). Operation shall be checked in terms of monitoring of BER/packet loss.
- (4) Testing of NMS (Craft Terminal) to demonstrate proper operation of all functions. All the standard features of the NMS (Craft Terminal) shall be demonstrated for proper functioning.
- (5) All the standard features of the existing NMS server (at RLDC/ SLDC) shall be demonstrated for proper functioning with respect to supplied communication equipment/ Node.
- (6) Demonstration of Protection switching and synchronization of equipment.
- (7) Comprehensive Cyber Security Tests in compliance to latest cyber security guidelines issued by CEA/MoP or any other govt department.

Annexure-I (A)
Standard Procedure for Type Test, FAT and
SAT

TYPE TEST PROCEDURE

SDH System

Table of Contents

- 1. General Test Set-up for BER Testing, Ethernet testing and Alarm Signaling :..... 3**
- 2. List of Test Equipment: 3**
- 3. Acceptance Criteria 3**
- 4. Temperature and Humidity Tests 5**
 - 4.1 Low Temperature test: Operation to Specification..... 5**
 - 4.2 Low Temperature test: Operation Without Damage..... 6**
 - 4.3 Dry Heat Test : Operation to Specification 7**
 - 4.4 Dry Heat test: Operation Without Damage 8**
 - 4.5 Damp Heat Test..... 9**
 - 4.6 Temperature Variation Test 10**
- 5. Power supply & EMI/EMC Test..... 11**
 - 5.1 Immunity Tests..... 11**
 - 5.1.1 Voltage fluctuations 12**
 - 5.1.2-a Voltage Dips 13**
 - 5.1.2-b Voltage Interruption 14**
 - 5.1.3 1.2/50 - 8/20 us Surge 15**
 - 5.1.4 Fast transient bursts 17**
 - 5.1.5 Damped Oscillatory Wave..... 18**
 - 5.1.6 Electrostatic Discharges 19**
 - 5.1.7 Radiated Electro Magnetic Field 20**
 - 5.2 Emission Tests 21**
 - 5.2.1 RF disturbance voltages 22**
 - 5.2.2 RF disturbance currents..... 23**
 - 5.2.3 RF Radiated Fields 24**
 - 5.3 Insulation Withstand Voltages..... 25**
 - 5.3.1 Insulation withstand voltage isolation test & 1.2/50 μ sec impulse voltage..... 25**
- 6. Mechanical Test..... 26**
 - 6.1 Mechanical Vibration Test..... 26**
 - 6.2 Shock test 27**
 - 6.3 Free Fall 28**

1. General Test Set-up for BER Testing, Ethernet testing and Alarm Signaling :

Test Set-up with detailed interconnection of cards and description for flow of signals to be provided.

2. List of Test Equipment:

Complete list of test equipment with serial number and validity of calibration to be provided.

3. Acceptance Criteria

The functional acceptance criteria for EUT are defined below:

N= the performance of equipment (EUT) in non-degraded mode (N1, N2 & N3)

N1=BER test

Evaluation criteria N for BER test, the test duration / period, are 15 mins. The pass criteria for "Operation to specification tests is that the number of bit error at the end of specified measurement period shall not exceed the max number of error generated by BER is equal 1×10^{-10}

N2= Alarm status:

Evaluation criteria N for alarm status. No effect \geq No change of status in the LCT & alarm contacts.

N3= Ethernet ping test:

Evaluation criteria N for Ethernet ping test. Perform ping test and there shall be no missing of pings during normal operation of ping test.

D= The performance of equipment (EUT) In degraded mode (D1, D2):

D1= BER test:

Evaluation criterion D for minor failure: Temporary degradation (with the equipment or link still in operational status) or loss of functions or performance which is self-recoverable with respect to the loss signal recovery condition.

The allowed number, of error \leq Error rate up to 10^{-6} error during the BER test.

D2= Alarm Status:

Evaluation criterion D for alarm status \Rightarrow change of alarm status allowed. Appearance of major and minor alarm on alarm contact. The alarms can be affected during the testing period but will be self-recoverable with respect to loss signal recovery condition.

EUT performance check:

Equipment checks are made before, during and after the test as detailed in test procedures.

If functional degradation is allowed during the test then after the test, equipment under test should behave normally (i.e. without degradation with no manual intervention)

4. Temperature and Humidity Tests

Test Number	4.1
Tender reference	
Test Name	Low Temperature test: Operation to Specification
Standard reference	IEC 60068-2-1 (2007) Method Ad
Test setup	As per figure shown in chapter General test setup
Test Procedure	The Climatic chamber shall be operated at Temperature = 0° C. The rate of change of temperature within the chamber shall be 0.5°C per minute. The test duration is 16 hours excluding thermal stabilization. The equipment shall be powered on after 1 hour of thermal stabilization.
Acceptance criteria	No degradation of performance is allowed during the test & after the test. According to evaluation criteria N1, N2 & N3 Section: <i>“3.acceptance criteria”</i>
Observation	<u>During test & After test: Non degraded mode</u> <u>For Equipment Under Test (EUT)</u> N1= BER test N2= Alarm status. N3= Ethernet ping test
Result	Pass [] Fail [] Not Applicable [] Remark []
Remark	
Date Name Signature	For Laboratory representative/Manufacturer For POWERGRID

Test Number	4.2
Tender reference	
Test Name	Low Temperature test: Operation Without Damage
Standard reference	IEC 60068-2-1 (2007) Method Ad
Test setup	As per figure shown in chapter General test setup
Test Procedure	The Climatic chamber shall be operated at Temperature = -10° C The rate of change of temperature within the chamber shall be 0.5°C per minute. The test duration is 72 hours excluding thermal stabilization. The equipment shall be powered on after 1 hour of thermal stabilization.
Acceptance criteria	Degradation of performance is allowed during the test. According to evaluation criteria D1, D2 & D3 of “3.acceptance criteria” . However there shall be no degradation of performance in the post-test according evaluation criteria N1, N2 & N3 of “3.acceptance criteria”
Observation	<u>During test : Degraded mode</u> <u>For Equipment Under Test (EUT)</u> D1= BER test D2= Alarm Status D3= Ethernet ping test <u>After the tests :Non-Degraded mode</u> <u>For Equipment Under Test (EUT)</u> N1= BER test N2= Alarm status N3= Ethernet ping test
Result	Pass [] Fail [] Not Applicable [] Remark []
Remark	
Date Name Signature	For Laboratory representative/Manufacturer For POWERGRID

Test Number	4.3
Tender reference	
Test Name	Dry Heat Test : Operation to Specification
Standard reference	IEC 60068-2-2 (2007) Method Bd
Test setup	As per figure shown in chapter General test setup
Test Procedure	The Climatic chamber shall be operated at Temperature = 45° C. The rate of change of temperature within the chamber shall be 0.5°C per minute. The test duration is 96 hours excluding thermal stabilization. The equipment shall be powered on after 1 hour of thermal stabilization.
Acceptance criteria	No degradation of performance is allowed during the test & after the test. According to evaluation criteria N1, N2 & N3 of <i>“3.acceptance criteria”</i>
Observation	<u>During the tests & After the test :Non-Degraded mode</u> <u>For Equipment Under Test (EUT)</u> N1= BER test N2= Alarm status N3= Ethernet ping test
Result	Pass [] Fail [] Not Applicable [] Remark []
Remark	
Date Name Signature	For Laboratory representative/Manufacturer For POWERGRID

Test Number	4.4
Tender reference	
Test Name	Dry Heat test: Operation Without Damage
Standard reference	IEC 60068-2-2 (2007) Method Bd
Test setup	As per figure shown in chapter General test setup
Test Procedure	The Climatic chamber shall be operated at Temperature = 55° C. The rate of change of temperature within the chamber shall be 0.5°C per minute. The test duration is 96 hours excluding thermal stabilization. The equipment shall be powered on after 1 hour of thermal stabilization.
Acceptance criteria	Degradation of performance is allowed during the test. According to evaluation criteria D1, D2 & D3 of “3.acceptance criteria” However there shall be no degradation of performance in the post-test according evaluation criteria N1, N2 & N3 of “3.acceptance criteria”
Observation	<u>During test : Degraded mode</u> <u>For Equipment Under Test (EUT)</u> D1= BER test D2= Alarm Status D3= Ethernet ping test <u>After the tests :Non-Degraded mode</u> <u>For Equipment Under Test (EUT)</u> N1= BER test N2= Alarm status N3= Ethernet ping test
Result	Pass [] Fail [] Not Applicable [] Remark []
Remark	
Date Name Signature	For Laboratory representative/Manufacturer For POWERGRID

Test Number	4.5
Tender reference	
Test Name	Damp Heat Test
Standard reference	IEC 60068-2-3
Test setup	As per figure shown in chapter General test setup
Test Procedure	The Climatic chamber shall be operated at Temperature = $(40 \pm 2) ^\circ\text{C}$ Humidity = $(93 \pm 3) \% \text{RH}$ The rate of change of temperature within the chamber shall be 0.5°C per minute. The test duration is 240 hours excluding thermal stabilization. The equipment shall be powered on after 1 hour of thermal stabilization.
Acceptance criteria	No degradation of performance is allowed during the test & after the test. According to evaluation criteria N1, N2 & N3 of “3.acceptance criteria”
Observation	<u>During the test & after the test :Non-Degraded mode</u> <u>For Equipment Under Test (EUT)</u> N1= BER test N2= Alarm status N3= Ethernet ping test
Result	Pass [] Fail [] Not Applicable [] Remark []
Remark	
Date Name Signature	For Laboratory representative/Manufacturer For POWERGRID

Test Number	4.6
Tender reference	
Test Name	Temperature Variation Test
Standard reference	IEC 60068-2-14 (2009) Method Nb
Test setup	As per figure shown in chapter General test setup
Test Procedure	The Climatic chamber shall be operated at Low temperature 0° C and at 45° C. The cycle test duration will be 3 hours for each temperature. The ramp is defined as 1°C/minute. The Number of cycle is 5. The equipment shall be powered on.
Acceptance criteria	Equipment performance is checked during the test & after the test and no degradation of performance is allowed during the test. The evaluation criteria N1, N2 & N3 of “3.acceptance criteria”
Observation	<u>During the test & after the test :Non-Degraded mode</u> <u>For Equipment Under Test (EUT)</u> N1= BER test N2= Alarm status N3= Ethernet ping test
Result	Pass [] Fail [] Not Applicable [] Remark []
Remark	
Date Name Signature	For Laboratory representative/Manufacturer For POWERGRID

5. Power supply & EMI/EMC Test

5.1 Immunity Tests

The list of Immunity tests are specified below:

Sr. No	Immunity test	AC Power Supply	DC Power Supply	Control & Signal	Telecom Lines	Parameters
1	Voltage Fluctuation	Yes	Yes	N/A	N/A	IEC 60870-2-1:1995, Table 11 Level:1
2	Voltage dips & Interruptions	Yes	Yes	N/A	N/A	
3	1.2/50-8/20us surge	Yes	Yes	Yes	N/A	IEC 60870-2-1:1995, Table 12 Level 1
4	Fast transient Burst	Yes	Yes	Yes	Yes	IEC 60870-2-1:1995, Table 12 Level 4
5	Damped Oscillator waves	Yes	Yes	Yes	Yes	IEC 60870-2-1:1995, Table 12 Level 1
6	Electrostatic Discharge	N/A	Yes			IEC 60870-2-1:1995, Table 13 Level 4
7	Radiated Electromagnetic field	N/A	Yes			IEC 60870-2-1:1995, Table 15 Level 3

Test Number	5.1.1
Tender reference	
Test Name	Voltage fluctuations
Standard reference	Table 11 of IEC 60870-2-1(1995) Level 1
Test setup	As per figure shown in chapter General test setup
Test Procedure	<p>This test is applicable on DC power supply port.</p> <p>The three condition (Un, Un+10% and Un-10%) will be conducted. Un= (-48 VDC)</p> <p>U=±8% during 2.5±0.5 sec Global cycle : 10s for one cycle Test of sequence of three constructive cycles (Zero second delay between each cycle).</p>
Acceptance criteria	No degradation of performance is allowed during and after the test. According to evaluation criteria N1, N2 & N3 of <i>“3.acceptance criteria”</i>
Observation	<p><u>During test & after the test non degraded mode</u></p> <p><u>For Equipment Under Test (EUT)</u></p> <p>N1= BER test</p> <p>N2= Alarm status</p> <p>N3= Ethernet ping test</p>
Result	Pass [] Fail [] Not Applicable [] Remark []
Remark	
Date Name Signature	<p>For Laboratory representative/Manufacturer</p> <p style="text-align: right;">For POWERGRID</p>

Test Number	5.1.2-a
Tender reference	
Test Name	Voltage Dips
Standard reference	Table 11 of IEC 60870-2-1(1995) Level 1/ IEC61000-4-11
Test setup	As per figure shown in chapter General test setup
Test Procedure	<p>This test is applicable on DC power supply port.</p> <p>The three condition (Un, Un+10% and Un-10%) will be conducted. Un= (-48 VDC)</p> <p>U=30% reduction: U= 14.4 for Un =-48V U=15.8 for Un =-48V+10% U=13.0Vfor Un=-48V-10%</p> <p>Duration of dips: ±0.5s One sequence of three dips with an interval of ten seconds.</p>
Acceptance criteria	<p>Transient disturbance, Degradation of performance is allowed during the test according the evaluation criteria D1, D2 & D3 as of chapter “3.acceptance criteria”</p> <p>However there shall be no degradation of performance in the post test according the evaluation criteria N1, N2 & N3 of “3.acceptance criteria”</p>
Observation	<p><u>During the test : Degraded mode</u></p> <p><u>For Equipment Under Test (EUT)</u></p> <p>D1= BER test</p> <p>D2= Alarm Status</p> <p>D3= Ethernet ping test</p> <p><u>After the tests :Non-Degraded mode</u></p> <p><u>For Equipment Under Test (EUT)</u></p> <p>N1= BER test</p> <p>N2= Alarm status</p> <p>N3= Ethernet ping test</p>
Result	Pass [] Fail [] Not Applicable [] Remark []
Remark	
Date Name Signature	For Laboratory representative/Manufacturer For POWERGRID

Test Number	5.1.2-b
Tender reference	
Test Name	Voltage Interruption
Standard reference	Table 11 of IEC 60870-2-1(1995) Level 1 and IEC 61000-4-11
Test setup	As per figure shown in chapter General test setup
Test Procedure	<p>This test is applicable on DC power supply port.</p> <p>The three condition (Un, Un+10% and Un-10%) will be conducted. Un= (-48 VDC)</p> <p>U=100% reduction: U= 45.6 for Un =-48V U=50.2 for Un =-48V+10% U=41.0V for Un=-48V-10% Duration of interruptions: 10ms One sequence of three interruptions with an interval of ten seconds.</p>
Acceptance criteria	<p>Transient disturbance, Degradation of performance is allowed during the test according the evaluation criteria D1, D2 & D3 as of chapter “3.acceptance criteria”</p> <p>However there shall be no degradation of performance in the post test according the evaluation criteria N1, N2 & N3 of “3.acceptance criteria”</p>
Observation	<p><u>During the test : Degraded mode</u></p> <p><u>For Equipment Under Test (EUT)</u></p> <p>D1= BER test D2= Alarm Status D3= Ethernet ping test</p> <p><u>After the tests :Non-Degraded mode</u></p> <p><u>For Equipment Under Test (EUT)</u></p> <p>N1= BER test N2= Alarm status N3= Ethernet ping test</p>
Result	Pass [] Fail [] Not Applicable [] Remark []
Remark	
Date Name Signature	For Laboratory representative/Manufacturer For POWERGRID

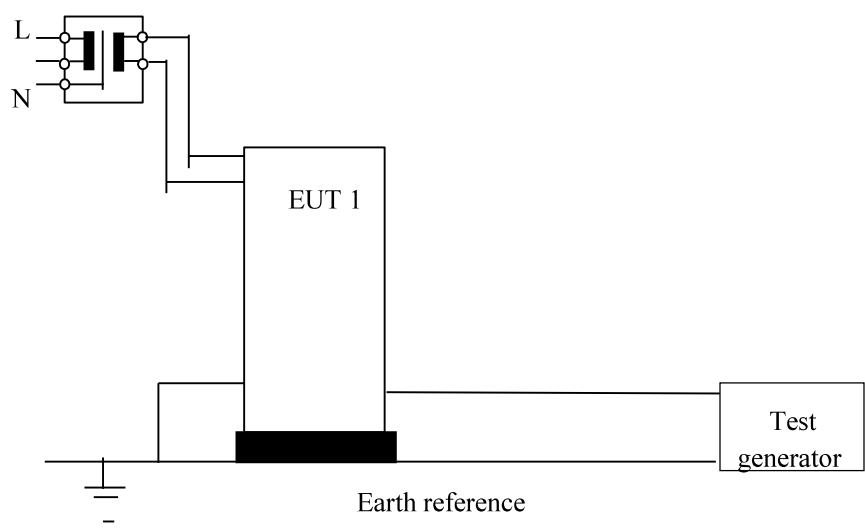
Test Number	5.1.3
Tender reference	
Test Name	1.2/50 - 8/20 us Surge
Standard reference	Table 12 of IEC 60870-2-1(1995) Level 1/IEC 61000-4-5
Test setup	As per figure shown in chapter General test setup
Test Procedure	<p>This test is applicable on</p> <ul style="list-style-type: none"> - DC power supply port. - control and signal lines -indoor telecommunication lines. <p>Wave : 1.2/50us – 8/20 us Level : 0.5KV common mode 0.25KV differential mode* (not applicable to balanced signal lines) 5 positive pulses and 5 negative pulses separated by 1 min are tested.</p> <p>Safety Insulation</p>  <p>Positive polarity and negative polarity are tested, 5 positive pulse and 5 negative pulse separated by 1 min.</p> <p>The differential mode will not be applied on shielded lines.</p>

Acceptance criteria	<p>Transient disturbance, Degradation of performance is allowed during the test according to the evaluation criteria D1 & D2 of “<i>3.acceptance criteria</i>”</p> <p>However there shall be no degradation of performance in the post test according to the evaluation criteria N1, N2 & N3 of “<i>3.acceptance criteria</i>”</p>
Observation	<p><u>During the test : Degraded mode</u></p> <p><u>For Equipment Under Test (EUT)</u></p> <p>D1= BER test</p> <p>D2= Alarm Status</p> <p><u>After the tests :Non-Degraded mode</u></p> <p><u>For Equipment Under Test (EUT)</u></p> <p>N1= BER test</p> <p>N2= Alarm status</p> <p>N3= Ethernet ping test</p>
Result	<p>Pass [] Fail [] Not Applicable [] Remark []</p>
Remark	
Date Name Signature	<p>For Laboratory representative/Manufacturer</p> <p style="text-align: right;">For POWERGRID</p>

Test Number	5.1.4
Tender reference	
Test Name	Fast transient bursts
Standard reference	Table 12 of IEC 60870-2-1(1995) Level 4 / IEC 61000-4-4
Test setup	As per figure shown in chapter General test setup
Test Procedure	<p>This test is applicable on</p> <ul style="list-style-type: none"> - DC power supply port. - control and signal lines -indoor telecommunication lines. <p>Level :</p> <ul style="list-style-type: none"> - DC Power Line : 4KV in common mode - Control & signal lines, telecom lines : 2KV in common mode <p>Frequency repetition : 5KHz Positive polarity & Negative polarity are tested. The test on the DC power line is realized with coupling/decoupling network. The test on the control & signal line, telecom lines is realized with a coupling clamp.</p>
Acceptance criteria	<p>Transient disturbance, Degradation of performance is allowed during the test according the evaluation criteria D1 & D2 as of chapter “3.acceptance criteria”</p> <p>However there shall be no degradation of performance in the post test according the evaluation criteria N1, N2 & N3 of “3.acceptance criteria”</p>
Observation	<p><u>During the test : Degraded mode</u></p> <p><u>For Equipment Under Test (EUT)</u></p> <p>D1= BER test</p> <p>D2= Alarm Status</p> <p><u>After the tests :Non-Degraded mode</u></p> <p><u>For Equipment Under Test (EUT)</u></p> <p>N1= BER test</p> <p>N2= Alarm status</p> <p>N3= Ethernet ping test</p>
Result	Pass [] Fail [] Not Applicable [] Remark []
Remark	
Date	For Laboratory representative/Manufacturer
Name	For POWERGRID
Signature	

Test Number	5.1.5
Tender reference	
Test Name	Damped Oscillatory Wave
Standard reference	Table 12 of IEC 60870-2-1 (1995) Level: 1 / IEC 61000-4-18
Test setup	As per figure shown in chapter General test setup
Test Procedure	<p>This test is applicable on</p> <ul style="list-style-type: none"> - the DC power supply - control & signal lines - Telecommunication lines. <p>Test level:</p> <ul style="list-style-type: none"> - 0.5KV: common mode voltage - 0.25KV: differential mode voltage <p>Period injection: 1µs (damped oscillatory frequency is 1MHz)</p> <p>Duration of test is at least 2s on each line under test.</p> <p>The minimum time interval between two successive tests is 10sec. acc. IEC 61000-4-1 chapter 8.</p> <p>Injection with the generator connected to a coupling /decoupling network, for shielded lines coupling directly onto the screen.</p> <p>DC power supply: positive pole is earthed on sub rack, therefore only common test line to earth is applied.</p> <p>Control & Signal lines and telecommunication lines: All are balanced lines, therefore acc. IEC 60870-2-1 the differential mode test is not applicable.</p>
Acceptance criteria	<p>Transient disturbance. Degradation of performance is allowed during the test according the evaluation criteria D1 & D2 as of chapter “3.acceptance criteria”.</p> <p>However there shall be no degradation of performance in the post test according the evaluation criteria N1, N2 & N3 of “3.acceptance criteria”</p>
Observation	<p><u>During the test : Degraded mode</u></p> <p><u>For Equipment Under Test (EUT)</u></p> <p>D1= BER test</p> <p>D2= Alarm Status</p> <p><u>After the tests :Non-Degraded mode</u></p> <p><u>For Equipment Under Test (EUT)</u></p> <p>N1= BER test</p> <p>N2= Alarm status</p> <p>N3= Ethernet ping test</p>
Result	Pass [] Fail [] Not Applicable [] Remark []
Remark	
Date Name Signature	For Laboratory representative/Manufacturer For POWERGRID

Test Number	5.1.6
Tender reference	
Test Name	Electrostatic Discharges
Standard reference	Table 13 of IEC 60870-2-1 (1995) Level: 4 /IEC61000-4-2
Test setup	As per figure shown in chapter General test setup
Test Procedure	<p>Contact discharge on vertical coupling plane and accessible metallic parts of the sub rack. Level: 8KV According to IEC 61000-4-2 all the intermediate levels (1 to 3) of 2KV, 4KV and 6KV are tested before the level 4 given by IEC 60870-2-1. Positive polarity and negative polarity are tested. Time between pulses is 1s. Ten discharges of each polarity are applied on each point tested.</p> <p>Note: The IEC 60870-2-1 does not specify tests for air discharge.</p>
Acceptance criteria	<p>Transient disturbance. Degradation of performance is allowed during the test according the evaluation criteria D1, D2 & D3 as of “3.acceptance criteria”.</p> <p>However there shall be no degradation of performance in the post test according the evaluation criteria N1, N2 & N3 of “3.acceptance criteria”</p>
Observation	<p><u>During the test : Degraded mode</u></p> <p><u>For Equipment Under Test (EUT)</u></p> <p>D1= BER test D2= Alarm Status D3= Ethernet ping test</p> <p><u>After the tests :Non-Degraded mode</u></p> <p><u>For Equipment Under Test (EUT)</u></p> <p>N1= BER test N2= Alarm status N3= Ethernet ping test</p>
Result	Pass [] Fail [] Not Applicable [] Remark []
Remark	
Date Name Signature	For Laboratory representative/Manufacturer For POWERGRID

5.2 Emission Tests

The list of Emission tests are specified below:

Sr. No	Emission Test	AC Power Supply	DC Power Supply	Control & Signal	Telecom Line	Parameters
1	RF disturbance voltage CISPR 22	Yes	Yes	N/A	N/A	Table 17 of IEC 60870-2-1: 1995 - Class : B
2	RF disturbance currents CISPR 22	N/A	N/A	N/A	Yes	
3	RF radiated field CISPR 22	Yes				

Test Number	5.2.1								
Tender reference									
Test Name	RF disturbance voltages								
Standard reference	CISPR 22 Table 17 of IEC 60870-2-1 (1995) Class: B								
Test setup	As per figure shown in chapter General test setup								
Test Procedure	<p>RF disturbance conducted voltages at the main ports. The voltage measurements are done with a receiver connected to a line impedance stabilization network [LISN]. The receiver has a peak average and quasi-peak detector. The test configuration for conducted measurements is floor standing equipment. Frequency range: 0.15 to 30 MHz Measurement unit: LISN Limits: Class B</p> <table border="0"> <thead> <tr> <th>Frequency Range (MHz)</th> <th>Quasi-peak Limits (dBμV) (Class B)</th> </tr> </thead> <tbody> <tr> <td>0.15 to 0.5</td> <td>66 to 56*</td> </tr> <tr> <td>0.5 to 5</td> <td>56</td> </tr> <tr> <td>5 to 30</td> <td>60</td> </tr> </tbody> </table> <p>*The limit have a linear decrease with a logarithm frequency variation</p>	Frequency Range (MHz)	Quasi-peak Limits (dB μ V) (Class B)	0.15 to 0.5	66 to 56*	0.5 to 5	56	5 to 30	60
Frequency Range (MHz)	Quasi-peak Limits (dB μ V) (Class B)								
0.15 to 0.5	66 to 56*								
0.5 to 5	56								
5 to 30	60								
Acceptance Criteria	The level must be lower or equal to the limits specified in the test procedure. It is an EMC measurement, so the performance is checked only after the test according the evaluation criteria N1, N2 & N3 of “3.acceptance criteria”								
Observation	<p><u>During test non degraded mode</u></p> <p><u>For Equipment Under Test (EUT)</u></p> <p>N1= BER test</p> <p>N2= Alarm status</p> <p>N3= Ethernet ping test</p>								
Result	Pass [] Fail [] Not Applicable [] Remark []								
Remark									
Date Name Signature	For Laboratory representative/Manufacturer For POWERGRID								

Test Number	5.2.2						
Tender reference							
Test Name	RF disturbance currents						
Standard reference	CISPR 22 Table 17 of IEC 60870-2-1 (1995) Class: B						
Test setup	As per figure shown in chapter General test setup						
Test Procedure	<p>RF disturbance current at the telecommunication ports. The measurements are done a/c to CISPR 22 C.1.2 with a receiver connected to a current probe. The receiver has a peak average and quasi-peak detector. A decoupling network (Ferrite) is placed on the cable of the telecommunication line connected to the bench. The test configuration for conducted measurements is floor standing equipment. In semi-anechoic Faraday room or ambient ground floor. Frequency range: 0.15 to 30 MHz Measurement unit: LISN Limits: Class B</p> <table border="0"> <thead> <tr> <th>Frequency Range (MHz)</th> <th>Quasi-peak Limits (dBμV) (Class B)</th> </tr> </thead> <tbody> <tr> <td>0.15 to 0.5</td> <td>40 to 30*</td> </tr> <tr> <td>5 to 30</td> <td>30</td> </tr> </tbody> </table> <p>*The limit have a linear decrease with a logarithm frequency variation The measurement shall be done with a peak detector. -if the disturbance levels are under the limits, the EUT (Equipment Under Test) is Declared in compliance with the specifications -if some disturbance levels are over the limits, detector QP (Quasi-Peak) is used to verify the compliance with the specification in the frequency range over the limit.</p>	Frequency Range (MHz)	Quasi-peak Limits (dB μ V) (Class B)	0.15 to 0.5	40 to 30*	5 to 30	30
Frequency Range (MHz)	Quasi-peak Limits (dB μ V) (Class B)						
0.15 to 0.5	40 to 30*						
5 to 30	30						
Acceptance Criteria	The level must be lower or equal to the limits specified in the test procedure. It is an EMC measurement, so the performance is checked only after the test according the evaluation criteria N1, N2 & N3 of "3.acceptance criteria"						
Observation	<p><u>During test non degraded mode</u></p> <p><u>For Equipment Under Test (EUT)</u></p> <p>N1= BER test</p> <p>N2= Alarm status</p> <p>N3= Ethernet ping test</p>						
Result	Pass [] Fail [] Not Applicable [] Remark []						
Remark							
Date	For Laboratory representative/Manufacturer						
Name	For POWERGRID						
Signature							

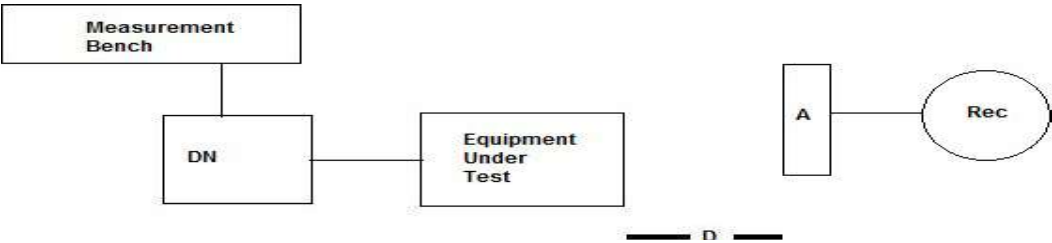
Test Number	5.2.3									
Tender reference										
Test Name	RF Radiated Fields									
Standard reference	Table 17 of IEC 60870-2-1 (1995) Class B and CISPR 22 (2008)									
Test setup	As per figure shown in chapter General test setup									
Test Procedure	<p>The measurements are done with a receiver connected to an antenna. The receiver has peak and quasi peak detectors. Decoupling networks (DN: Ferrite) are placed on the cables connected to the bench.</p>  <p>The distance (D) between the EUT and the antenna is 3m. Only the EUT and the antenna are in the semi-anechoic chamber.</p> <p>Frequency range: 30 to 1000MHz Measurements at 3 meters. Antenna: Broadband antenna (30 to 1000MHz) Polarization: Both polarizations are measured Turntable: 360⁰ Antenna mast: 1 to 4 meters above the ground plane Semi-anechoic Faraday room</p> <table border="1"> <thead> <tr> <th>Frequency Range (MHz)</th> <th>Quasi-peak Limits (dBuV/m) (Vertical & Horizontal polarization)</th> <th>Quasi-peak Limits (Class B)</th> </tr> </thead> <tbody> <tr> <td>30 to 230</td> <td></td> <td>40</td> </tr> <tr> <td>230 to 1000</td> <td></td> <td>47</td> </tr> </tbody> </table> <p>Note: For reason of ambient noise at 10m in open area test site, the measurements will be done in a semi-anechoic Faraday room at 3m: according to chapter 10.2.1 of CISPR 22 IEC: 1997. According to CISPR 22, “An inversely proportionality factor of 20 dB/decade should be used to normalize the measured data to the specified distance for determining compliance.” So it’s necessary to add 10dB to the limits at 10meters indicted in the CISPR-22.</p>	Frequency Range (MHz)	Quasi-peak Limits (dBuV/m) (Vertical & Horizontal polarization)	Quasi-peak Limits (Class B)	30 to 230		40	230 to 1000		47
Frequency Range (MHz)	Quasi-peak Limits (dBuV/m) (Vertical & Horizontal polarization)	Quasi-peak Limits (Class B)								
30 to 230		40								
230 to 1000		47								
Acceptance Criteria	The level must be lower or equal to the limits specified in the test procedure. It is an EMC measurement, so the performance is checked only after the test according the evaluation criteria N1, N2 & N3 of “ 3.acceptance criteria ”									
Observation	<p><u>During test non degraded mode</u></p> <p><u>For Equipment Under Test (EUT)</u></p> <p>N1= BER test</p> <p>N2= Alarm status</p> <p>N3= Ethernet ping test</p>									
Result	Pass [] Fail [] Not Applicable [] Remark []									
Remark										
Date	For Laboratory representative/Manufacturer									
Name	For POWERGRID									
Signature										

5.3 Insulation Withstand Voltages

As per section 6 of IEC 60870-2-1. Recommended Class: VW1 of Table 18

Test Number	5.3.1
Tender reference	
Test Name	Insulation withstand voltage isolation test & 1.2/50 µsec impulse voltage
Standard reference	IEC 60870-2-1 (1995) VW1 of Table 18
Test setup	As per figure shown in chapter General test setup
Test Procedure	<p>This test is specified on DC power supply, control and signal ports and Telecommunication port as per table of 8 insulation with stand voltages class: VWI for DC power supply below 60V</p> <p>The test to applied are :</p> <ul style="list-style-type: none"> a) Power supply with stand voltage : 0.5 KVrms b) Impulse: 1KV Peak for 1.2/50us impulse voltage; 5 pulse with negative polarity and 5 pulse with alternating polarity.
Acceptance criteria	<p>During the test, the equipment is powered off.</p> <p>After the test, the equipment is required to function correctly in non- degraded mode according the evaluation criteria N1, N2 & N3 of “3.acceptance criteria”</p>
Observation	<p><u>After the test: Non degraded mode</u></p> <p><u>For Equipment Under Test</u></p> <p><u>(EUT)</u></p> <p>N1= BER test</p> <p>N2= Alarm</p> <p>status</p> <p>N3= Ethernet ping test</p>
Result	Pass [] Fail [] Not Applicable [] Remark []
Remark	
Date Name Signature	For Laboratory representative/Manufacturer For POWERGRID

6. Mechanical Test

Test Number	6.1
Tender reference	
Test Name	Mechanical Vibration Test
Standard reference	IEC Publication 60068-2-6
Test setup	As per figure shown in General test setup
Test Procedure	<p>6.1.1 5 to 9 Hz 0.3mm 9 to 200 Hz 1m/s² 1 sweep cycle per all the three axis</p> <p>6.1.2 5 to 9 Hz 3.5mm 9 to 200 Hz 10m/s² 200 to 500 Hz 15m/s² 5 sweep cycle per all the three axis</p> <p>6.1.3 5 to 9 Hz 0.3mm 9 to 200 Hz 1m/s² 1 sweep cycle per all the three axis</p> <p>Before commencing the vibration test, the EUT is switched on and functional test shall be done for 15 min period. During the test the equipment is powered off and packed. Vibration test will be conducted in the sequence 8.1, 8.2.1 and 8.1. After Completion of vibration test, EUT shall be unpacked and functional test shall be done for 15 min period.</p>
Acceptance criteria	After the test, the equipment is required to function correctly in non- degraded mode according the evaluation criteria N1, N2 & N3 of “ 3.acceptance criteria ”
Observation	<p><u>After the test: Non degraded mode</u></p> <p><u>For Equipment Under Test (EUT)</u></p> <p>N1= BER test</p> <p>N2= Alarm status</p> <p>N3= Ethernet ping test</p>
Result	Pass [] Fail [] Not Applicable [] Remark []
Remark	
Date Name Signature	For Laboratory representative/Manufacturer For POWERGRID

Test Number	6.2
Tender reference	
Test Name	Shock test
Standard reference	IEC Publication 60068-2-27
Test setup	As per figure shown in General test setup
Test Procedure	Acceleration amplitude 294 m/s ² . Duration: 18 ms Direction: Three Axis Number of shocks: 3 in each direction Direction of Shocks: 6 direction Total Number of shocks: 18
Acceptance criteria	After the test, the equipment is required to function correctly in non- degraded mode according the evaluation criteria N1, N2 & N3 of <i>“3.acceptance criteria”</i>
Observation	<u>After the test: Non degraded mode</u> <u>For Equipment Under Test (EUT)</u> N1= BER test N2= Alarm status N3= Ethernet ping test
Result	Pass [] Fail [] Not Applicable [] Remark []
Remark	
Date Name Signature	For Laboratory representative/Manufacturer For POWERGRID

FACTORY ACCEPTANCE TEST PROCEDURE FOR OPTICAL FIBRE (ITU-T G.652D) APPLICABLE STANDARD EIA/TIA 455

Sl. No.	Test Name	Test Procedure	Acceptance Criteria
1	Attenuation Coefficient	EIA/TIA 455-78A	≤0.35dB/km (1310nm) ≤0.21dB/km (1550nm)
2	Point Discontinuities of Attenuation	EIA/TIA 455-59	≤0.1 dB
3	Attenuation at Water Peak	EIA/TIA-455-78A	≤0.34dB/km at 1383nm
4	Chromatic Dispersion	EIA/TIA 455 -168A/169A /175A	≤18 ps/(nm·km) at 1550nm
			≤3.5 ps/(nm·km) from 1288 nm to 1339nm
			≤5.3 ps/ (nm·km) from 1271nm to 1360nm
			Zero Dispersion wavelength: 1300nm – 1324nm; Zero Dispersion slope: ≤ 0.092 ps/nm ² .km
5	Core - Clad Concentricity Error	EIA/TIA 455- 176	≤0.5 μm
6	Cladding Diameter	EIA/TIA 455-176	125 ± 0.7 μm
7	Fibre Tensile Proof Testing	EIA/TIA 455-31B	≥1.0%, 1 sec. ≥ 0.69 Gpa (100kpsi)

Note: The test report of the above tests for the fibres are to be carried out by the Fibre Manufacturer and used in the Approach cable shall be shown to the inspector during Approach cable FAT and shall be submitted along with the Approach cable FAT reports.

**FACTORY ACCEPTANCE TEST PROCEDURE
FOR APPROACH CABLES**

Sl. No.	Factory Acceptance Test	Sampling plan
1	Attenuation Coefficient at 1310nm,1550nm	10% of offered FO approach cable drums/lot and 100% of fibers in selected FO approach cable drums.(Minimum 2)
2	Point discontinuities	10% of offered FO approach cable drums/lot and 100% of fibers in selected FO approach cable drums. (Minimum 2)
3	Visual material verification and dimensional checks as per approved DRS & drawings	Quantity verification: 100% of offered material.

IEC 60793-1-40, EIA/TIA-455-59 & EIA/TIA-455-61 and ITU-T G.652 D

Test Location :

Manufacturer :

Test Objective : To measure the optical attenuation at wavelengths 1310 nm and 1550 nm & Point discontinuities at both wavelength of 1310 nm and 1550nm.

Test Set-ups:

Prepare the sample under test as per the figure showing below the test setup. The test bench is connected with Optical Time Domain Reflectometer (OTDR) to measure the value of attenuation coefficient and Point discontinuities

Test Procedure:

1. Connect the test sample either to the instrument or to one end of end dead-zone fiber (if used).
Connect the other end of the dead-zone fiber (if used) to the instrument.
2. If the accurate locations of point defects are to be recorded, the effective group delay index of the test sample is required. If this value is not known, use FOTP-60 (Method A) to determine it.
3. Enter OTDR parameters such as source wavelength, pulse duration, length range, and signal averaging into the instrument, along with the test sample effective group index. The values of some of these parameters may be present in the instrument.
4. Adjust the instrument to display a backscatter signal from the test sample. It may be advantageous to begin with coarse vertical and horizontal scaling to maximize the length displayed. An example is given in Figure.
5. Examine the OTDR signal along the test sample for point defects. If increased resolution is needed, adjust the graphical display, if possible, to expand the section of interest to larger scale (exercising care to assure that proper reading of the true signal can still be distinguished from the noise points).
6. To determine that a point defect (rather than an attenuation non-uniformity situation) exist observe the area in question using two different pulse durations. If the shape of the loss or gain changes with the pulse duration, the anomaly is a point defect. If the shape does not change, the anomaly shall be considered to be attenuation non-uniformity to be measured by FOTP-61.
7. Report any point defect deviations which exceed the values specified in the Detail Specification. Describe the nature of these faults (e.g. apparent loss or gain, reflection, duration, etc.) as required by the Detail Specification.
 - 7.1 Determine the defect location, if required, by placing a cursor at the beginning (or at another point specified by the OTDR manufacturer) of a power rise or drop, this may be difficult to do at a drop. Obtain the distance coordinate via the alphanumeric display.
 - 7.2 Obtain the apparent loss or gain of the defect, if required, by the method described by the OTDR manufacturer. Some instruments required placement of a pair of cursors on each side of the defect. The two best-fit straight lines (from a two-point or least-squares fit for each) are extrapolated to the defect location. If available, the linear fit method should be

FAT Procedure for Fibre Optic Approach Cable

chosen. The vertical separation of the lines gives the apparent loss or gain .Note any reflection peak.

- 7.3 When possible, repeat the test for a single launched into the test sample in the opposite direction. A more accurate loss estimate (and the elimination of apparent gain) is made by averaging readings taken directionally at the same wavelength .This eliminates the effect of any backscatter different for the fiber sections on both side of the defect.
- 7.4 Repeat the test at another wavelength.

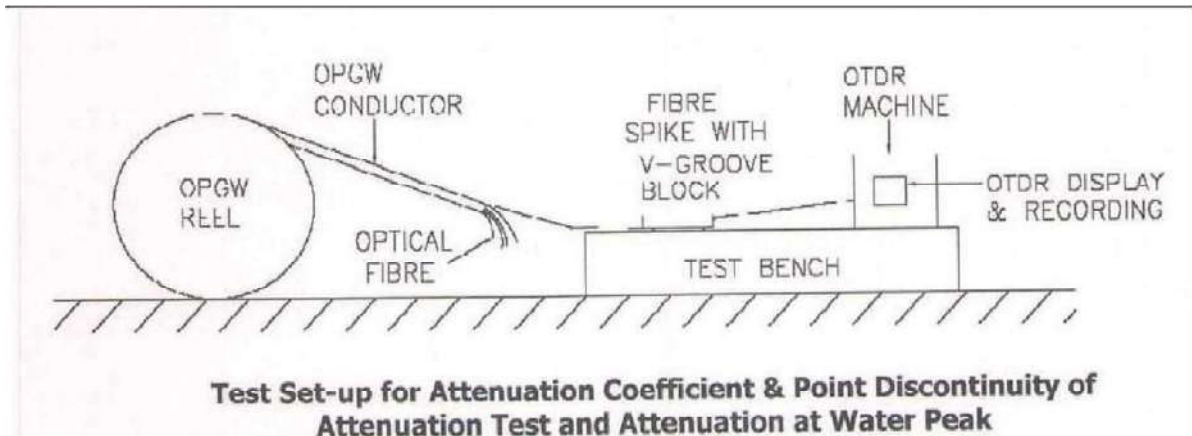

Acceptance Criteria:

For Attenuation

Wavelength	Attenuation
1310 nm	< 0.35 dB/Km
1550 nm	<0.21 dB/Km

For Point Discontinuity: Attenuation of fiber shall be uniform throughout its length such that there are no point discontinuity in excess of 0.1dB.

ATTENUATION AND POINT DISCONTINUITY

Ring Mark	Fiber id	At 1310 nm				Ring Mark	At 1550 nm			
		Optical Attenuation	Point Discontinuity	Pass or Fail	Remarks		Optical Attenuation	Point Discontinuity	Pass or Fail	Remarks

Observations, if any:

Test Results:

The attenuation and point discontinuity measured have met/not met the acceptance criteria.

Tested by:
(Sign with date)

Witnessed by:
(Sign with date)

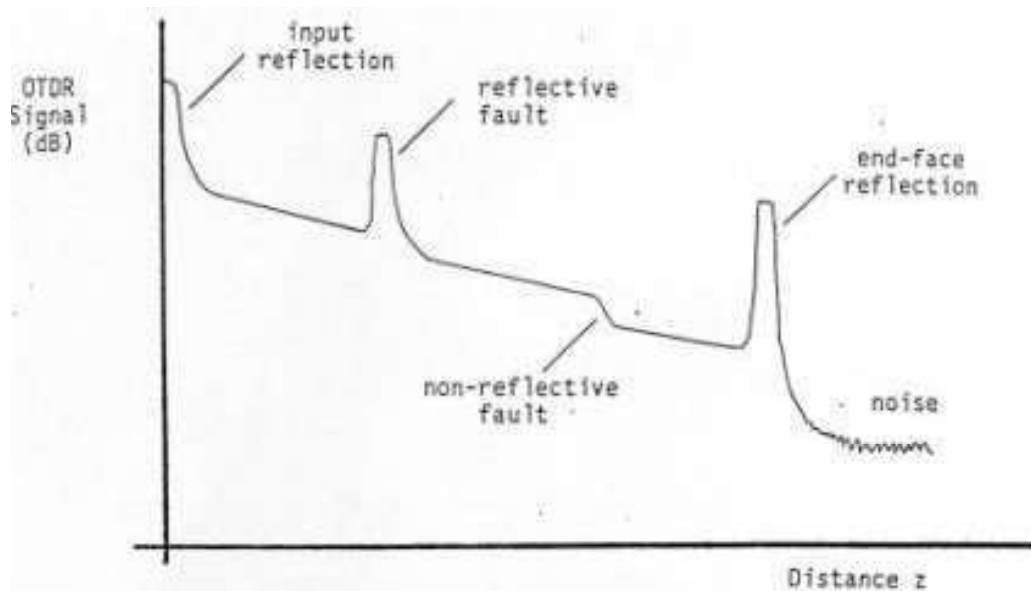

Figure 1. Schematic of an OTDR Trace. Point defects with apparent loss are shown, one reflective and one non-reflective.

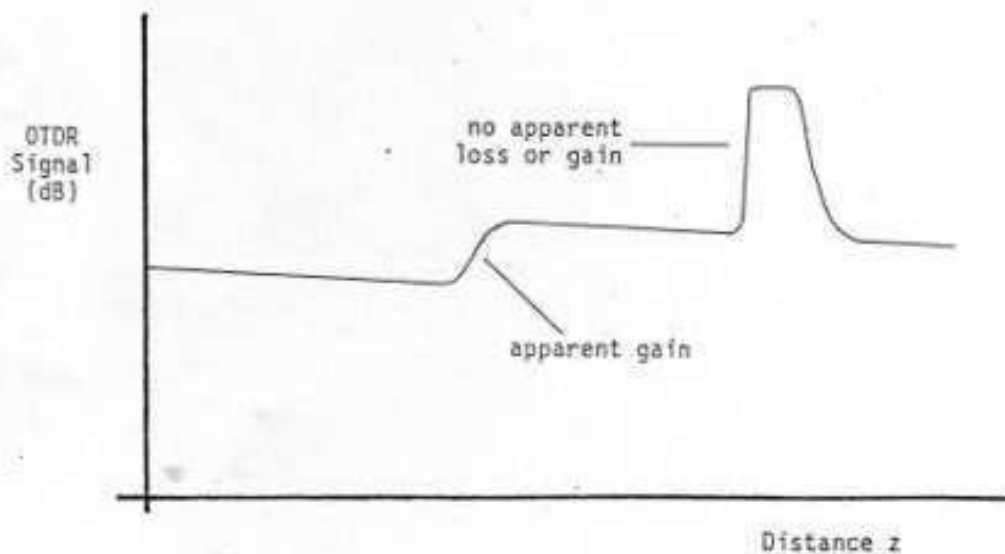

Figure 2. Schematic of an expanded OTDR trace. Two point defects are shown, one with apparent gain, and another with no apparent loss or gain.

2. VISUAL MATERIAL VERIFICATION, CABLE CONSTRUCTION AND DIMENSIONAL CHECKS

Test Standard: IEC 60793 & 60794, EIA/TIA-598

Test Location:

Manufacturer:

Cable Type: Approach Cable.

Reference Doc: Approved DRS & Drawings of Fiber Optical Approach Cable.

Objective: To measure the Visual material verification, Cable construction and dimensional checks for Fiber Optical Approach Cable.

Test Procedure:

The physical/dimensional measurements of the individual parts of the cable shall be taken with suitable measuring device and verified against the approved DRS/Drawings

Drum Checks:

- Physical Verification for the 100% offered quantity of the offered reels/drums shall be carried out. 1.
- 2. 100% physical verification of sealing of cable ends with end caps, check for provision of spare cable caps for each drum.
- 3. 100% verification of Sealing/Pasting the drum details over the end cap with transparent tape.
- 4. Verification of drum details properly printed and pasted on each drum suitably as per approved document **Checks**

on Approach cable: The below to be verified as per approved DRS/Drawings for both Fiber Optical Approach Cable.

S.NO.	Description	Acceptance Criteria
1.	No. of Fiber	AS per approved DRS& drawings
2.	Buffer Tube Quantiv(Nos.)/Diameter	AS per approved DRS& drawings
3.	No. of Fibers per tube(Nos.)	AS per approved DRS& drawings
4.	Filling Material	AS per approved DRS& drawings
5.	Strengthening Member	AS per approved DRS& drawings
6.	Outside Jacket Coating	AS per approved DRS& drawings
7.	Outside Jacket Thickness	AS per approved DRS& drawings
8.	Armoring Tape provided	AS per approved DRS& drawings
9.	Weight(kg/km)	AS per approved DRS& drawings
10.	Overall Diameter	AS per approved DRS& drawings
11.	Identification of colors of fibers/tube	AS per approved DRS& drawings
12.	Other physical/Technical parameters	AS per approved DRS& drawings

Acceptance Criteria: Visual material verification, Cable construction and dimensional checks shall be as per approved DRS /drawings.

Observations, if any:

Test Results: The Fiber Optic Approach cables as teats met tested met the requirement as approved DRS & Drawings.

Test by:
(sign with date)

Witnessed by:
(sign with date)

FACTORY ACCEPTANCE TEST PROCEDURE (FAT)

SDH EQUIPMENT along with Optical Amplifier

TABLE OF CONTENTS

TPS-FOTS-001: REVIEW OF CALIBRATION OR MANUFACTURING CERTIFICATES..... 3

TPS-FOTS-002: INVENTORY VERIFICATION 4

TPS-FOTS-003: OPTICAL TX OUTPUT POWER MEASUREMENT 5

TPS-FOTS-004: RECEIVER SENSITIVITY MEASUREMENT 7

TPS-FOTS-005: SDH OPTICAL UNITS - LASER SAFETY CHECK 9

TPS-FOTS-006: ELECTRICAL INTERFACE INPUT JITTER TOLERANCE..... 11

TPS-FOTS-007: ELECTRICAL (2 MBIT/S) INTERFACE OUTPUT JITTER GENERATION 13

TPS-FOTS-008: ELECTRICAL INTERFACE LINE RATE TOLERANCE 15

TPS-FOTS-009: PROTECTION SWITCHING OF REDUNDANT CARDS 17

TPS-FOTS-010: MULTIPLEX SECTION PROTECTION IN SDH NETWORK 19

TPS-FOTS-011: SUB NETWORK CONNECTION PROTECTION (SNCP) IN SDH NETWORK 22

TPS-FOTS-012: MEASUREMENT OF ORDER WIRE CHANNEL..... 24

TPS-FOTS-013: SDH EQUIPMENT (STM 16 & STM 4) - POWER SUPPLY TEST 26

TPS-FOTS-014: ETHERNET PARAMETERS MEASUREMENTS..... 29

TPS-FOTS-015: ETHERNET PROVISIONING AND VLAN SEPARATION TEST 32

TPS-FOTS-016: E1 (2 MBIT/S) INTERFACE UNIT - BIT ERROR RATE 34

TPS-FOTS-017: SDH NETWORK - NMS & LCT FUNCTIONALITY TEST 36

TPS-FOTS-018: 150, 175, 200, 225, 250 KM LINK OPTICAL AMPLIFIER TEST 40

TPS-FOTS-019: PRE-AMPLIFIER RECEIVER SENSITIVITY MEASUREMENT 42

TPS-FOTS-020: POWER SUPPLY RANGE MEASUREMENT OF OPTICAL AMPLIFIERS..... 44

TPS-FOTS-021: ELECTRICAL INTERFACE TEST 46

TPS-FOTS-022: GENERATION OF BIT ERROR CURVE 48

TPS-FOTS-023: TEST FOR SPARE CARDS AND SPARE SLOTS 50

TPS-FOTS-024: RANDOM INSPECTION TO VERIFY THE ACCURACY OF DOCUMENTS 52

TPS-FOTS-025: CABLE COMPENSATION ON ETHERNET INTERFACE 53

TPS-FOTS-026: SPECTRAL CHARACTERISTICS & CENTRAL WAVELENGTH (OPTICAL INTERFACE) 55

TPS-FOTS-027: DATA CHANNEL TESTING 57

TPS-FOTS-028: Comprehensive Cyber Security Tests in compliance to latest cyber security guidelines issued by CEA/MoP or any other govt department.

TPS-FOTS-001: Review of Calibration or Manufacturing Certificates

Equipment Under Test : **Test Equipment**

Test Parameters : **Review of Calibration or Manufacturing Certificates**

1.0 TEST DESCRIPTION

Prior to the commencement of system testing, the calibration certificates of all the test equipment as listed in the TPS for performing the system factory acceptance testing will be reviewed by inspection team.

2.0 LIST OF TEST EQUIPMENT

Test Equipment	Make	Model No.	Serial No.	Calibration Valid till Date

3.0 TEST RESULT RECORD

Copies of the calibration certificates will be attached along with this test sheet.

Status

() Tested – OK _____

() Tested – Failed _____

Remarks

Tested By _____ : Witnessed By _____ :

(Manufacturer)

(POWERGRID)/Constituent

Date _____ : Date _____ :

TPS-FOTS-002: Inventory Verification

Equipment Under Test : **SDH Equipment**

Test Parameters : **Inventory Verification**

TEST DESCRIPTION

The aim of this test is to verify station wise inventory of offered equipment.

2.0 TEST PROCEDURE

1. Check station wise cards/units along with sub rack.
2. Verify it with the quantity of offered equipment as per approved BOM.

3.0 TEST RESULT RECORD

The quantity should be found as per the approved BOM.

Status

() Tested – OK _____

() Tested – Failed _____

Remarks

Tested By : _____ Witnessed By : _____
(Manufacturer) (POWERGRID)/Constituent

Date : _____ Date : _____

TPS-FOTS-003: Optical Tx Output Power Measurement

Equipment Under Test : **SDH Equipment Optical Units**

Test Parameters : **Optical Output Power**

1.0 TEST DESCRIPTION

The purpose of this test is to determine whether the optical interface cards (STM-16 and STM-4) operate at designed level of optical output power range. This test ensures that the laser providing the optical output has adequate optical output power performance in compliance with ITU-T G.957.

2.0 TEST EQUIPMENT

1. Optical Power Meter
2. Local Craft Terminal (LCT)
3. Low loss optical patch cord

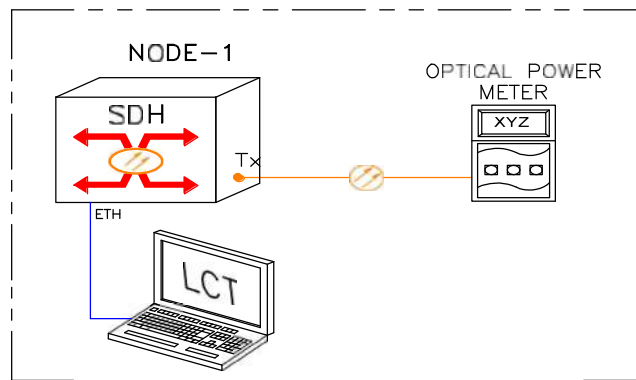
3.0 TEST SETUP**4.0 TEST PROCEDURE**

1. Choose SDH equipment and plug optical cards of different application code. Use Low loss optical patch cord to connect the output optical port of the tested SDH node with the input port of Optical Power Meter in turn to test the output power.
2. Connect the optical output port of the SDH to the input port of the optical power meter with low loss optical patch cord to test the output power as shown in above figure.
3. Set the optical power meter to the specified wavelength.
4. Measure the output power level in dBm.
5. Record the result showing on the optical power meter.

5.0 TEST RESULT RECORD

*As per approved DRS

No.	Optical interfaces/ Card tested as per approved BOQ	Min (dBm)*	Max (dBm)*	Actual (dBm)

6.0 Acceptance Criteria:

The measured optical output power should be within the limits as per G.957

Status

() Tested – OK _____
 () Tested – Failed _____

Remarks

Tested By : _____ Witnessed By : _____
 (Manufacturer) (POWERGRID)/Constituent

Date : _____ Date : _____

TPS-FOTS-004: Receiver Sensitivity Measurement

Equipment Under Test : **SDH Equipment Optical Units**

Test Parameters : **Receiver Sensitivity Measurement**

1.0 TEST DESCRIPTION

This test is performed to test the optical card of the SDH unit to ensure the minimum and maximum optical power level (sensitivity) of optical signal that can be detected and correctly re-constructed in compliance with ITU-T G.957.

2.0 TEST EQUIPMENT

4. Optical Power Meter
5. Variable Optical Attenuator (VOA)
6. SDH Analyzer
7. Local Craft Terminal (LCT)
8. Low loss optical patch cord

3.0 TEST SETUP

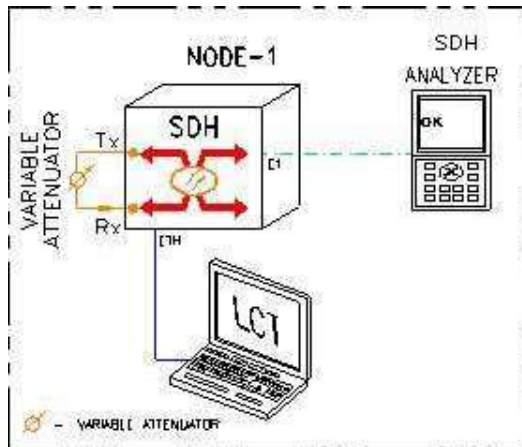

4.0 TEST PROCEDURE

Receiver Sensitivity

1. Choose the SDH equipment with STM-16 and STM-4 optical interface cards. Use optical patch cords to connect the optical ports to SDH Analyzer and VOA as shown in above figure.
2. Setup the SDH Analyzer for BER testing.
3. Increase the attenuation till any error occurs at the tested optical interface card.
4. Decrease the attenuation gradually, so that the error just goes off.
5. The test should continue for a period of 90 seconds.

6. Disconnect the optical patch cord from the tested port (Rx) and connect to the optical power meter.
7. Record the result showing on the optical power meter, is the receive sensitivity.

5.0 TEST RESULT RECORD

Sr. No.	Node / Station	Slot No./ Port No./Sr.No.	Module Type	Receiver Sensitivity as per ITU-T G.957 (dBm)	Actual (dBm)
1					
2					
3					

Status

() Tested – OK _____

() Tested – Failed _____

Remarks

Tested By _____ : _____
 (Manufacturer)

Witnessed By _____ : _____
 (POWERGRID)/Constituent

Date _____ : _____

Date _____ : _____

TPS-FOTS-005: SDH Optical Units - Laser Safety Check

Equipment Under Test : **SDH Optical Units**

Test Parameters : **Laser Safety Check**

1.0 TEST DESCRIPTION

The aim of this test is to check the Laser safety (ALS: Automatic Laser Shutdown) functionality of the SDH optical interfaces. In this test it is checked if the laser shuts down automatically when the fiber link is broken.

2.0 TEST EQUIPMENT

1. SDH Analyzer
2. Optical Attenuators
3. Local Craft Terminal (LCT)
4. Low loss optical patch cord

3.0 TEST SETUP

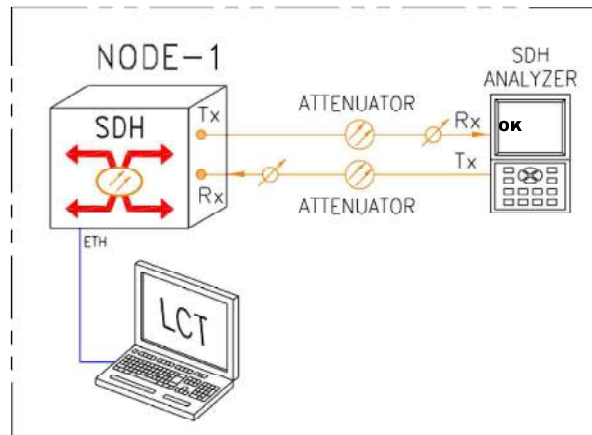

4.0 TEST PROCEDURE

1. Set up E1 / Ethernet traffic and loop back the STM-4/16 optical path.
2. Enable ALS in the optical ports (STM-16/STM-4) used.
3. Inject LOS alarm by breaking Rx fiber.
4. Since ALS is enabled, the transmitter will switch OFF after 500 ms or more.
5. Measure the optical power output at Tx of STM-4/16 optical card, no power to be shown.
6. Restore the Rx fiber, the alarm to be cleared and the transmitter should be ON.
7. Record the result.

5.0 TEST RESULT RECORD

Sr. No.	Node / Station	Slot No. / Port No/Sr. no.	Optical Interface	Test Description	Specification	Results (OK/ Not OK)
1				ALS	Optical transmitter should shut off as per G.664 when the optical port receives LOS alarm.	
2				ALS	Optical transmitter should shut off as per G.664 when the optical port receives LOS alarm.	
3				ALS	Optical transmitter should shut off as per G.664 when the optical port receives LOS alarm.	

Status

() Tested – OK _____
 () Tested – Failed _____

Remarks

Tested By _____ : _____ Witnessed By _____ : _____
 (Manufacturer) (POWERGRID)
 Date _____ : _____ Date _____ : _____

TPS-FOTS-006: Electrical Interface Input Jitter Tolerance

Equipment Under Test : **E1 (2 Mbit/s) Interface Unit**

Test Parameters : **Electrical (E1) Interface Input Jitter Tolerance**

1.0 TEST DESCRIPTION

Measurement of input jitter tolerance of the electrical interface in compliance with ITU-T G.823

2.0 TEST EQUIPMENT

1. E1 Analyzer
2. Local Craft Terminal (LCT)
3. Connecting Cables

3.0 TEST SETUP

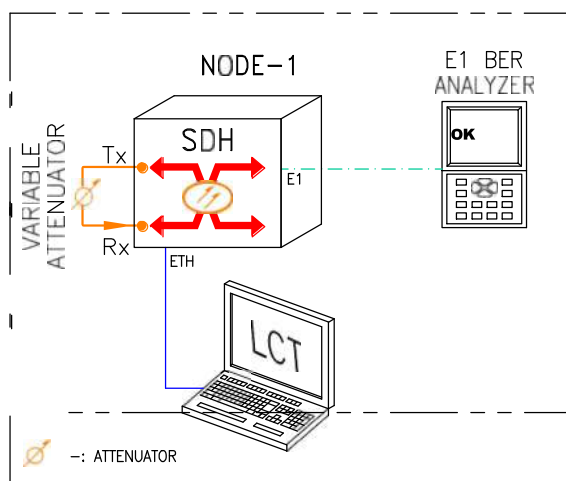

4.0 TEST PROCEDURE

1. Choose one SDH node with E1 interface card (DUT). Use cable to connect the electrical output port of the tested node to the electrical input port of E1 Analyzer and connect the electrical input port of the tested node to the electrical output port of E1 Analyzer.
2. Select relevant rate for E1 Analyzer Rx / Tx port.
3. Set up E1Traffic from E1 Analyzer.
4. Loop back the optical port of the SDH equipment.
5. With the loop-back, there shall be no bit errors reported in the test set.
6. Setup the E1 Analyzer for jitter tolerance measurement. Choose an ITU-T G.823 mask.
7. Now go to Jitter Test Menu and perform Jitter Tolerance test by selecting Auto Tolerance Menu from the options (In Auto Jitter Tolerance test, the E1 Analyzer automatically increases the Jitter

until the point of failure and plots the point on the graph and then proceeds to the next Jitter Frequency).

8. Print out the plot of the result.

5.0 TEST RESULTS

Input jitter tolerance of E1 electrical interfaces:

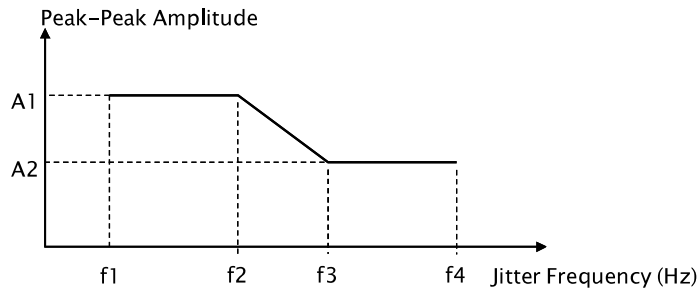

Measured value should be as per ITU-T G.823. The test results will be attached with this test record.

Status

() Tested – OK _____

() Tested – Failed _____

Node Details

Station _____

Unit Type _____

Remarks

Tested By _____ : _____
 (Manufacturer)

Witnessed By _____ : _____
 (POWERGRID)/Constituent

Date _____ : _____

Date _____ : _____

TPS-FOTS-007: Electrical (2 Mbit/s) Interface Output Jitter Generation

Equipment Under Test : **E1 (2 Mbit/s) Interface Unit**

Test Parameters : **Electrical (2 Mbit/s) Interface Output Jitter Generation**

1.0 TEST DESCRIPTION

The aim of this test is to measure the jitter in 2Mbit/s output signal and check if it is as per ITU-T G.823.

2.0 TEST EQUIPMENT

1. E1 Analyzer
2. Local Craft Terminal (LCT)
3. Low loss optical patch cord

3.0 TEST SETUP

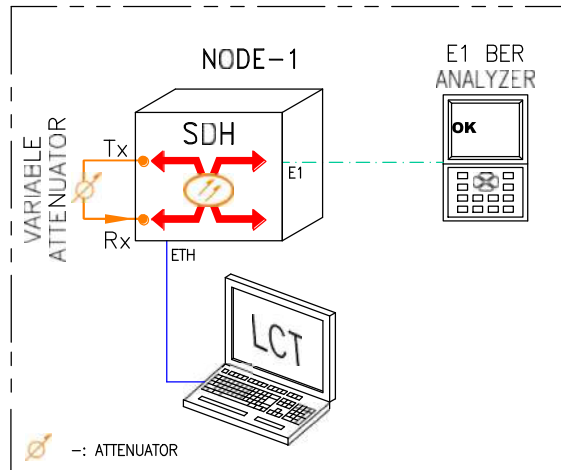

4.0 TEST PROCEDURE

1. Make setup as shown in above figure.
2. Set up E1 Traffic from E1 Analyzer.
3. Loop back the optical port of the SDH equipment.
4. With the loop-back, there shall be no bit errors reported in the test set.
5. Apply E1 Analyzer to send test signals, and configure proper measurement filter at the receiving end.
6. Perform continuous test with duration of 60 seconds.
7. Record the measured maximum peak-to-peak value of jitter.

5.0 TEST RESULTS

Interface	Measuring Filter		Peak-peak Jitter
2048 Kbit/s (E1 Interface)	20Hz to 100kHz (LP+HP1)	Standard	1.50 UI
		Measured	
	18kHz to 100kHz (LP+HP2)	Standard	0.2 UI
		Measured	

The measured value should not exceed the limits given in the above table.

Status

() Tested – OK _____

() Tested – Failed _____

Node Details

Station _____

Unit Type _____

Remarks

Tested By _____ : _____
 (Manufacturer)

Witnessed By _____ : _____
 (POWERGRID)

Date _____ : _____

Date _____ : _____

TPS-FOTS-008: Electrical Interface Line Rate Tolerance

Equipment Under Test : **E1 (2 Mbit/s) Interface Unit**

Test Parameters : **Electrical (2 Mbit/s) Interface Line Rate Tolerance**

1.0 TEST DESCRIPTION

Measurement of line rate tolerance of the Electrical interface in compliance with ITU-T G.703

2.0 TEST EQUIPMENT

1. SDH Analyzer
2. Local Craft Terminal (LCT)

3.0 TEST SETUP

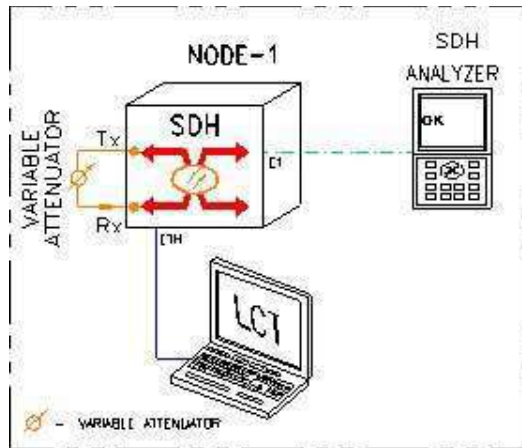

4.0 TEST PROCEDURE

1. Set up E1 traffic from SDH Analyzer and make suitable cross-connection using LCT.
2. Loop back optical port of SDH by means of an attenuator.
3. Setup the SDH Analyzer for BER testing.
4. Vary the offset ppm value up to the tolerable value in both positive and negative sides.
5. Record the result.

5.0 TEST RESULTS

Interface	Line Rate Tolerance	Measurement
E1 (2 Mbit/s)	2.048Mbits/s ± 50 ppm	

There should not be any errors during the test.

Status

() Tested – OK _____

() Tested – Failed _____

Node Details

Station _____

Unit Type _____

Remarks

Tested By _____ : _____
(Manufacturer)

Witnessed By _____ : _____
(POWERGRID)/Constituent

Date _____ : _____

Date _____ : _____

TPS-FOTS-009: Protection Switching of Redundant Cards

Equipment Under Test : **SDH Equipment**

Test Parameters : **Equipment Protection**

1.0 TEST DESCRIPTION

To verify that the protection switching mechanisms for the Common Control & Cross-connect card of SDH node is working properly.

2.0 TEST EQUIPMENT

1. E1 Analyzer
2. Local Craft Terminal (LCT)
3. Low loss optical patch cord

3.0 TEST SETUP

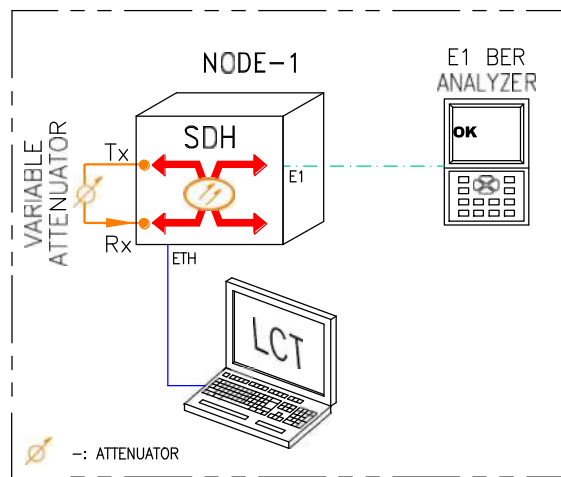

4.0 TEST PROCEDURE

- a. Connect the electrical (Tx, Rx) of the SDH equipment to the E1 Analyzer.
- b. Loop back the optical port (Tx, Rx) of the SDH equipment.
- c. Create the cross connection between the electrical port and the optical port.
- d. Unplug the active Common Control & Cross-connect card of SDH node from card slot.
- e. The standby Common Control & Cross-connect card should take over, and the traffic should be restored.

5.0 TEST RESULTS

Traffic is restored even if one of the Common Control & Cross-connect cards failed.

Status

() Tested – OK _____

() Tested – Failed _____

Node Details

Station _____

Unit Type _____

Remarks

Tested By : _____
(Manufacturer)

Witnessed By : _____
(POWERGRID)/Constituent

Date : _____

Date : _____

TPS-FOTS-010: Multiplex Section Protection in SDH Network

Equipment Under Test : **SDH Transmission System**

Test Parameters : **Multiplex Section Protection**

1.0 TEST DESCRIPTION

The aim of this test to check the multiplex section protection scheme in compliance with the ITU-T G.841.

2.0 TEST EQUIPMENT

- 1. E1 Analyzer
- 2. Ethernet Analyzer
- 3. Cables and accessories

3.0 TEST SETUP

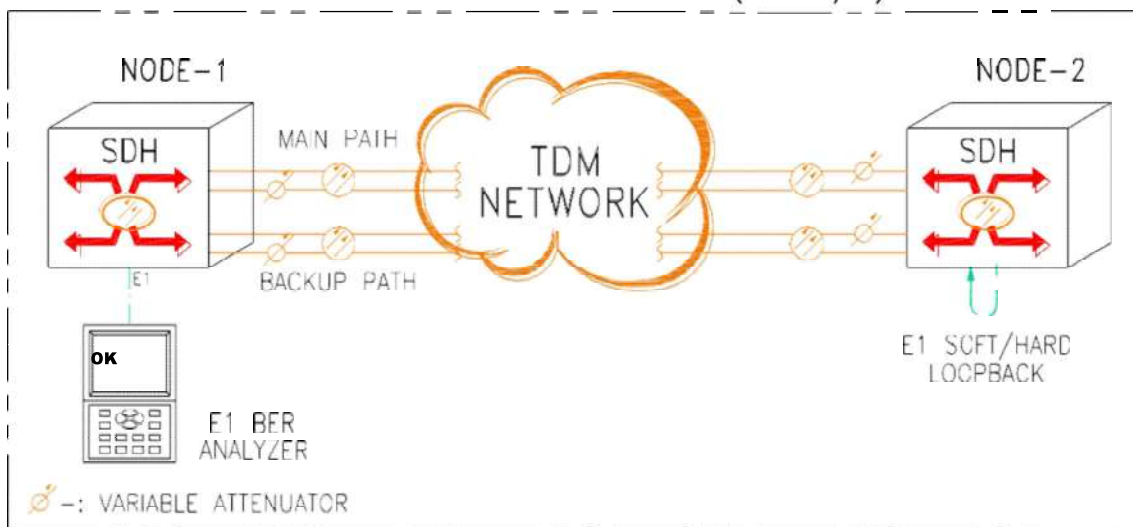

Figure 1: MSP Protection Test E1

MULTIPLEX SECTION PROTECTION ETHERNET TEST (SDH N/W)

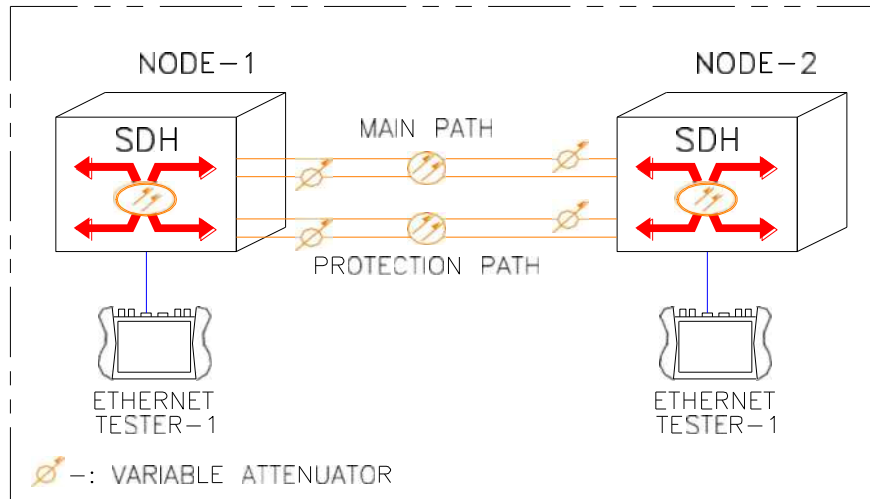

Figure 2: MSP Protection Test Ethernet

4.0 TEST PROCEDURE**E1 Protection test**

- Make the test setup as shown in Figure 1.
- Create the required cross connections with Switching Protection in the SDH Nodes across the link through which the testing will be done.
- Set up an E1 from the E1 Analyzer and connect it to the local SDH node.
- Provide a soft loop / hard loop on the configured E1 of the remote SDH node.
- The tester will show "OK" with the loop back on the remote node concerning the configured channel.
- With the loop-back, there shall be no bit errors.
- Break main link between the two stations and verify that E1 signal is through over standby link.
- Verify the Cross-connect redundancy, by jacking out one of the redundant module at a time.
- Tabulate the observation in test result table at Point 1 , 2 and 3.

Ethernet Protection test

- Make the test setup as shown in Figure 2.
- Create the required cross connections with Switching Protection in the SDH Nodes across the link through which the testing will be done.
- Set up an E1 / Ethernet Traffic from the Ethernet Analyzer and connect it to the local SDH node.
- Provide a soft loop on the configured Ethernet of the remote Ethernet Tester.
- The tester will show "OK" with the loop back on the remote node concerning the configured channel.
- With the loop-back, there shall be errors.

- Break main link between the two stations and verify that Ethernet signal is through over standby link.
- Verify the Cross-connect redundancy, by jacking out one of the redundant module at a time.
- Tabulate the observation in test result table at Point 4 & 5.

5.0 TEST RESULT

Sr. No.	Test Description	Results (OK / Not OK)
1	Switching to standby path is occurred when working path failed for E1 test	
2	Switching can be auto-restored after the fail disappeared for E1 test.	
3	Switching time should be less than 50ms (Applicable to APS test)	
4	Switching to standby path is occurred when working path failed for Ethernet test.	
5	Switching can be auto-restored after the fail disappeared for Ethernet test.	

Status

() Tested – OK _____

() Tested – Failed _____

Remarks

Tested By _____ : _____ Witnessed By _____ : _____

(Manufacturer)

(POWERGRID)/Constituent

Date _____ : _____ Date _____ : _____

TPS-FOTS-011: Sub Network Connection Protection (SNCP) in SDH Network

Equipment Under Test : **Fiber Optic Transmission System**

Test Parameters : **Sub Network Connection Protection (SNCP)**

1.0 TEST DESCRIPTION

The aim of this test to check the sub network connection protection scheme in compliance with the ITU-T G.841.

2.0 TEST EQUIPMENT

1. E1 Analyzer
2. Cables and accessories

3.0 TEST SETUP

Figure 1: SNCP Protection Test

4.0 TEST PROCEDURE

- Make the test setup as shown in Figure 1.
- Create the E1 channel from STM node-1 to STM Node-2 via STM optical path.
- Configure the protection path for the E1 channel between Node-1 to Node-2 using sub-network connection protection in that particular ring via Node-4 to Node-3 STM path as shown in above figure.
- Connect the tested port (E1) at Node-1 to the E1 Analyzer and loop back the corresponding tributary at Node-2.

- Setup the BER Tester for BER testing. While the BER test is in progress, now break the working fiber link (STM path) between Node-1 & Node-2, verify whether the protection to alternate path (Node-3 and Node-4 i.e., optical path in ring) occurred correctly.
- Restore the working fiber links; verify whether the switching can be auto restored after the failure disappeared.
- Tabulate the results as under Section 5.0.

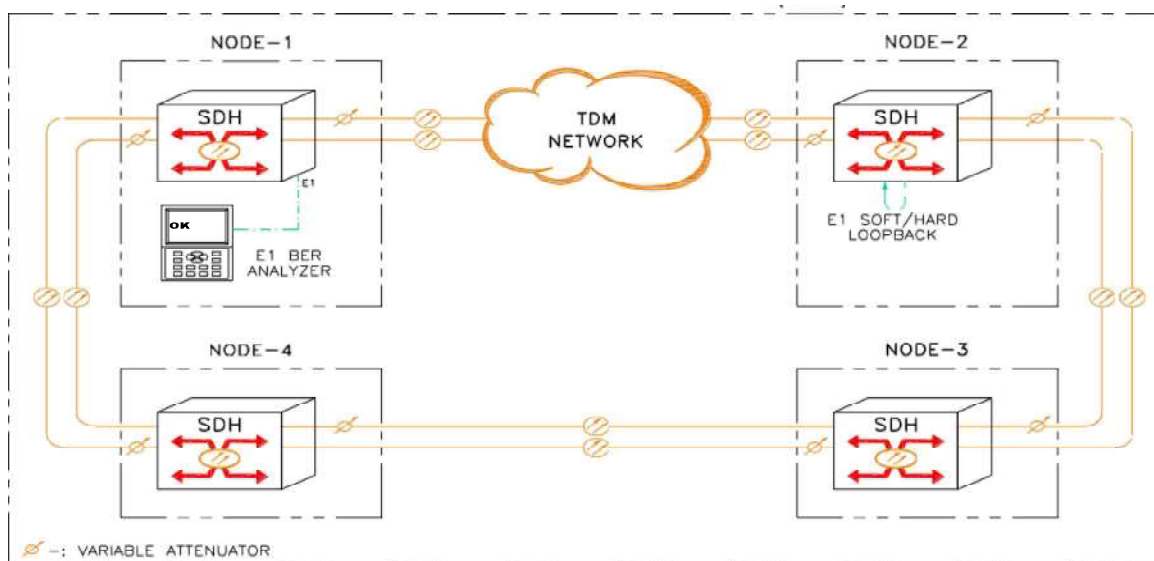
5.0 TEST RESULT

Sr. No.	Test Description	Results (OK / Not OK)
1	Switching to alternate path is occurred when working path failed.	
2	Switching can be auto-restored after the fail disappeared.	
3	Switching time should be less than 50ms.	

Status

() Tested – OK _____

() Tested – Failed _____

Remarks

Tested By _____ : _____ Witnessed By _____ : _____
 (Manufacturer) (POWERGRID)/Constituent

Date _____ : _____ Date _____ : _____

TPS-FOTS-012: Measurement of Order Wire channel

Equipment Under Test : **SDH Optical Units**
 Test Parameters : **EOW Station to Station Dial Testing**

1.0 TEST DESCRIPTION

The purpose of this test will be an operational test to be performed for checking the satisfactory EOW operation.

2.0 TEST EQUIPMENT

1. EOW Phone.
2. LAN Cable

3.0 TEST SETUP

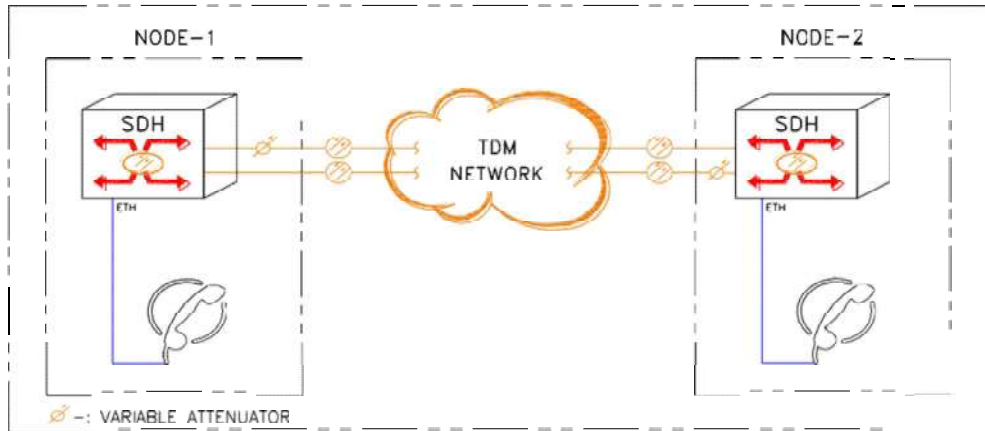

Figure 1: EOW Functionality

4.0 TEST PROCEDURE

- By using the EOW telephone connected on SDH system, dial the telephone number of any other SDH station and check the EOW operation. Repeat the test for other stations.
- Check the operation of EOW as specified above and tabulate the results as under section 5

5.0 TEST RESULT RECORD

Sr.No.	Station	EOW Number	Station	EOW Number	Results (OK / NOT OK)
1					
2					

Status

() Tested – OK _____

() Tested – Failed _____

Remarks

Tested By _____ : _____
(Manufacturer)

Witnessed By _____ : _____
(POWERGRID)/Constituent

Date _____ : _____

Date _____ : _____

TPS-FOTS-013: SDH Equipment (STM 16 & STM 4) - Power Supply Test

Equipment Under Test : **SDH Equipment (STM 16 & STM 4)**

Test Parameters : **Power Supply Test**

1.0 TEST DESCRIPTION

The purpose of this test is to check the operation of SDH equipment in power supply conditions as listed below of a fully equipped equipment rack.

1. Test of equipment against input power variation from -40 to -60V DC.
2. Automatic recovery of the equipment when the power supply is restored to normal.
3. Reverse power protection test (polarity reversal) and automatic recovery.
4. Short circuit protection
5. Power supply protection test

2.0 TEST EQUIPMENT

1. Variable DC power supply
2. SDH Analyzer
3. Local Craft Terminal (LCT)
4. Cables and accessories

3.0 TEST SETUP

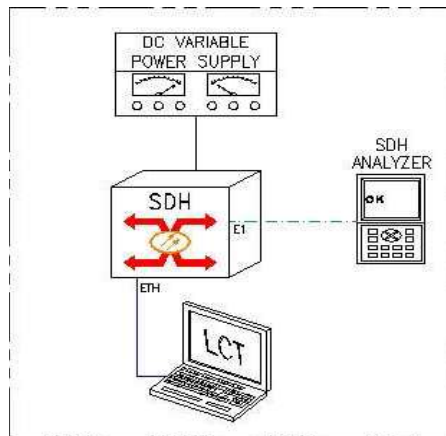

Figure 2: Test set up for Variable Power supply Measurement test

4.0 TEST PROCEDURE

1. **Maximum Voltage, Minimum Voltage Test**

- a) Connect the input supply cables from variable power supply unit and the SDH Analyzer to the equipment sub-rack as shown in above figure.
- b) Adjust the output voltage of the variable power supply unit to -48 VDC and switch ON the SDH equipment.
- c) Vary the input power supply from -48 Volts to -60 Volts (in steps) at this point check the operation of SDH equipment with the help of SDH Analyzer and it should operate as in normal condition.
- d) Restore the power supply to normal i.e. -48 Volts and check the operation of SDH equipment. It should operate as in normal condition.
- e) Vary the input power supply from -48 Volts to -40 Volts (in steps) at this point check the operation of SDH equipment with the help of SDH Analyzer and it should operate as in normal condition.
- f) Restore the power supply to normal again i.e. -48 Volts and check the operation of SDH equipment. It should operate as in normal condition.
- g) Switch off the power supply and the switch on the power supply and check the operation of SDH equipment. It should operate as in normal condition.

2. Power Supply Protection Test

- a) Connect both the input power supply cables to the power inputs of the SDH equipment.
- b) Switch ON the equipment power supply.
- c) Disconnect one of the power supply input from the power interface panel, the equipment should operate in normal condition.

3. Reverse Power Supply Protection Test

- a) Apply power with reverse polarity at the input, check if the system is protected against reverse polarity connection of the input supply. Restore the normal power supply connection and check if the system gets powered ON and working.

4. Short Circuit Protection

Verify whether the power supply card shuts off on short circuit

5.0 TEST RESULT RECORD

Sr. No.	Test Description	Specification	Results (OK/NOT OK)
1	Operation of SDH equipment at -48 volt DC input supply	No bit errors	

2	Operation of SDH equipment at -60 volt DC input supply	No bit errors	
3	Operation of SDH equipment at -40 Volt DC input supply	No bit errors	
4	Power supply protection	Should be protected.	
5	Reverse polarity connection	Should be protected.	
6	Short Circuit test	Should be protected.	

Status

() Tested – OK _____

() Tested – Failed _____

Node Details

Station _____

Unit Type _____

Remarks

Tested By : _____
 (Manufacturer)

Witnessed By : _____
 (POWERGRID)/Constituent

Date : _____

Date : _____

TPS-FOTS-014: Ethernet Parameters Measurements

Equipment Under Test : **SDH Equipment along with Ethernet Interface Unit**

Test Parameters : **Throughput, Latency and Frame Loss Test**

1.0 TEST DESCRIPTION

To verify that the Ethernet card is in compliance with the specifications of IEEE 802.3. The ethernet link shall be tested for Throughput, Latency and Frame loss as per RFC2544.

2.0 TEST EQUIPMENT

1. Ethernet Analyzer
2. Local Craft Terminal (LCT)
3. Low loss optical patch cord & CAT cable

3.0 TEST SETUP

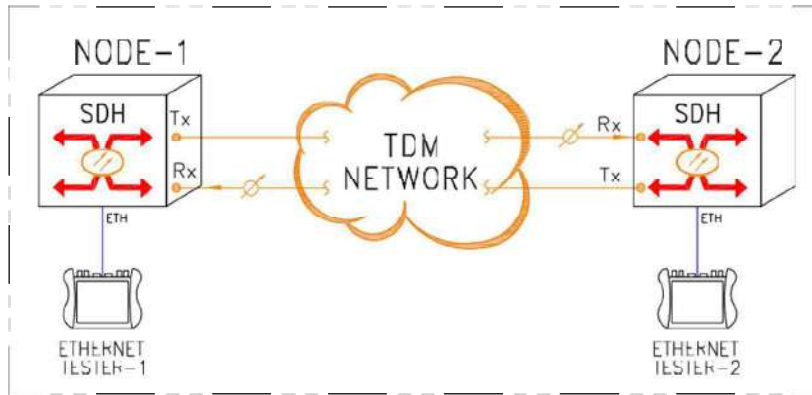

4.0 TEST PROCEDURE

1. Data Channel (Throughput) Test

- a. Connect the two (2) SDH nodes (Node-1 & 2) with optical patch cords as shown in above figure.
- b. Connect one of the Ethernet Analyzer to LAN port-1 of Node-1 & another Ethernet Analyzer to LAN port-1 of Node-2 with CAT cable.
- c. Set the LAN ports of both the nodes on "100M full duplex" mode.
- d. Set the test duration to 10 seconds and the length of test frame to 1518 bytes. Measure the throughput.
- e. Observe and record the test results.

2. Latency Measurement

- a. Connect the two (2) SDH nodes (Node-1 & 2) with optical patch cords as shown in above figure.

- b. Connect one of the Ethernet Analyzer to LAN port-1 of Node-1 & another Ethernet Analyzer to LAN port-1 of Node-2 with CAT cable.
- c. Set the LAN ports of both the nodes on "100M full duplex" mode.
- d. Set the test duration to 10 seconds and the length of test frame to 1518 bytes respectively. Test the latency.
- e. Observe and record the test results.

3. Frame Loss

- a. Connect the two (2) SDH nodes (Node-1 & 2) with optical patch cords as shown in above figure.
- b. Connect one of the Ethernet Analyzer to LAN port-1 of Node-1 & another Ethernet Analyzer to LAN port-1 of Node-2 with CAT cable.
- c. Set the LAN ports of both the nodes on "100M full duplex" mode.
- d. Set the test duration to 10 seconds and the length of test frame to 1518 bytes respectively. Test the Frame Loss.
- e. There should be no frame loss, record the test results.

5.0 TEST RESULTS

Throughput

The throughput of the Ethernet card should not be less than the bandwidth configured.

Sr. No.	Bandwidth (Mbit/s)	Measured Throughput	Data Channel Results (OK / Not OK)
1	2		
2	4		
3	10		
4	100		

Latency

Sr. No.	Bandwidth (Mbit/s)	Measured Latency	Results (OK / Not OK)
1	2		
2	4		
3	10		
4	100		

Frame Loss

Sr. No.	Bandwidth (Mbit/s)	Throughput Rate%	Frame Loss	Results (OK / Not OK)
1	2			
2	4			
3	10			
4	100			

Status

() Tested – OK _____

() Tested – Failed _____

Node - 1 Details

Station _____

Unit Type _____

Node - 2 Details

Station _____

Unit Type _____

Remarks

Tested By : _____
 (Manufacturer)

Witnessed By : _____
 (POWERGRID)/Constituent

Date : _____

Date : _____

TPS-FOTS-015: Ethernet Provisioning and VLAN Separation Test

Equipment Under Test : **SDH Transmission System**

Test Parameters : **Ethernet Provisioning and VLAN Separation**

TEST DESCRIPTION

The purpose of this test is to check the provisioning of Ethernet channels and configuration of VLAN per application. Enable traffic separation at layer 2 thus segregating Broadcast domains based VLAN membership

2.0 TEST EQUIPMENT

1. Ethernet Analyzer
2. Cables and accessories

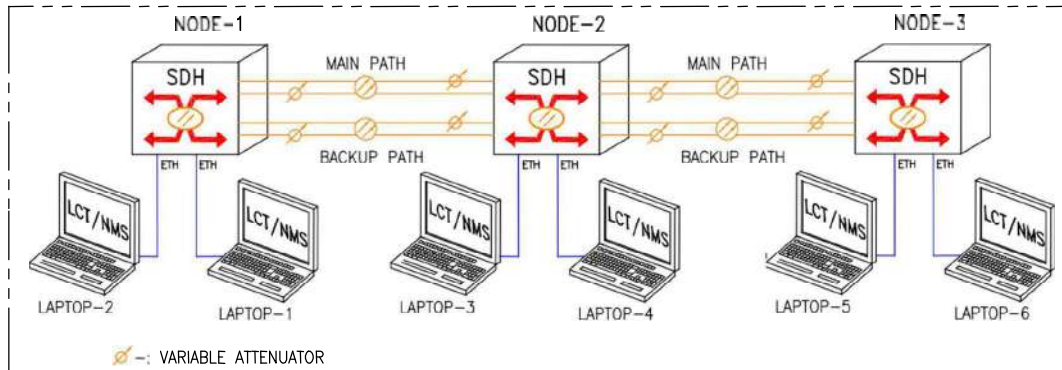
3.0 TEST SETUP**4.0 TEST PROCEDURE**

- Make the test setup as per Figure 1.
- Create the required cross connections to provision an Ethernet link and assignment of VLAN in the SDH Nodes across the link through which the testing will be done.
- Ping response should be present between the two laptops.
- Tabulate the results as under Section 5
- Verify that laptops connected on same VLAN can communicate and laptops on separate VLAN's cannot communicate with each other.
- Repeat the procedure on other Ethernet Channels (if required).

5.0 TEST RESULT

The tested ports can receive continuous packet each other and WAN bandwidth capacity should be as per Ethernet channel plan.

Sr. No	Local Station	Remote Station	Slot No. / Port No.		VLAN Configuration (OK / Not OK)
			Local	Remote	
1			SL___/P___	SL___/P___	
2			SL___/P___	SL___/P___	
3			SL___/P___	SL___/P___	
4			SL___/P___	SL___/P___	

Status

() Tested – OK _____

() Tested – Failed _____

Remarks

Tested By _____ : _____ Witnessed By _____ : _____
 (Manufacturer) (POWERGRID)/Constituent
 Date _____ : _____ Date _____ : _____

TPS-FOTS-016: E1 (2 Mbit/s) Interface Unit - Bit Error Rate

Equipment Under Test : **E1 (2 Mbit/s) Interface Unit**

Test Parameters : **Bit Error Rate**

TEST DESCRIPTION

The purpose of this test is to check Bit Error Rate (BER) in E1 (2 Mbit/s) interface unit of SDH node in compliance with ITU-T G.821.

2.0 TEST EQUIPMENT

1. SDH Analyzer
2. Local Craft Terminal (LCT)
3. Low loss optical patch cord

3.0 TEST SETUP

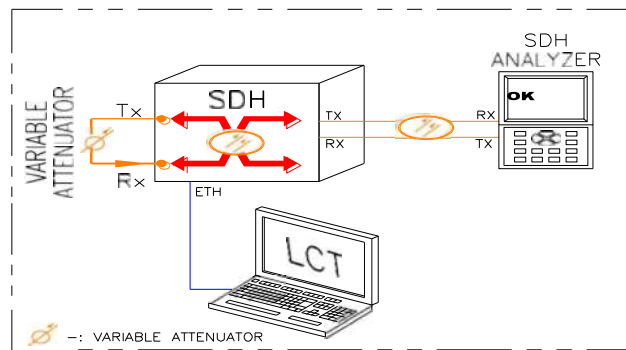

4.0 TEST PROCEDURE

1. The test set-up will be as indicated in above figure.
2. Connect the SDH Analyzer to the configured E1 of the 2M tributary card of STM-4/16 node.
3. Create the cross connection to terminate E1 from one of the optical port. Apply soft or hard loop back on the optical port using fixed attenuator.
4. Set-up SDH Analyzer to perform 2 Mbit/s BER testing.
5. Commence the BER testing and run the BER test for 10 Minutes duration.
6. Record the result. The test results recorded will be as per ITU-T recommendation G.821.

5.0 TEST RESULTS

Test Description	Results (OK / NOT OK)
BER measurement on 2 Mbit/s (E1) port	BER result should be better than 10^{-10}

Status

() Tested – OK _____
() Tested – Failed _____

Node Details

Station _____

Unit Type _____

Remarks

Tested By _____ : _____ Witnessed By _____ : _____
(Manufacturer) (POWERGRID)/Constituent
Date _____ : _____ Date _____ : _____

TPS-FOTS-017: SDH Network - NMS & LCT Functionality Test

Equipment Under Test : **SDH Network Management System & LCT**

Test Parameters : **NMS & LCT Functionality Test**

1.0 TEST DESCRIPTION

The purpose of this test is to confirm proper operation of network management system (TNMS) and Local Craft Terminal (LCT) for SDH system for this project as indicated below.

2.0 TEST EQUIPMENT

- SDH Network Management System (TNMS)
- Local Craft terminal (LCT)
- SDH Analyzer
- Cables and accessories

3.0 TEST SETUP

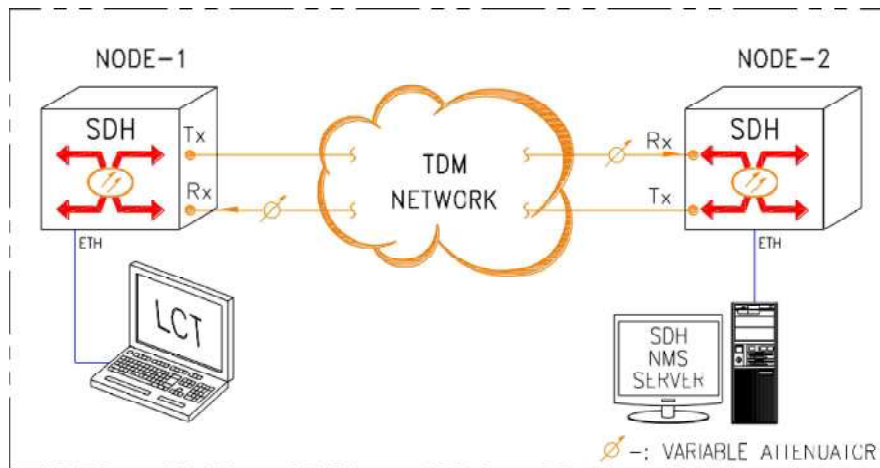

Figure 1: Remote Node Management

4.0 TEST PROCEDURE

CONFIGURATION MANAGEMENT

- Connect the TNMS system with the management interface of SDH equipment by using Ethernet cable.
- Ensure the SDH equipment is working.
- Login NMS as user of advanced level.
- Check the NMS whether it can establish and maintain the network topology.

- Check the NMS whether it provides the tools for planning, establishing and changing the static equipment configuration, this item can be conducted by changing some parameters & cross connection of the SDH equipment.
- Check the NMS whether it provide verification testing to support new equipment installation, this can be tested by adding a new NE.
- For creating the cross connection, establish the cross connection between any of the two ports in the same or different card.

FAULT MANAGEMENT

- Connect the TNMS system with the management interface of SDH equipment by using Ethernet cable.
- Ensure the SDH equipment is working.
- Login NMS as user of advanced level.
- Generate the various alarms; check the NMS for relevant alarm status.
- For example, pull out one card from SDH sub-rack; check the NMS for alarm of that fault.
- Insert the card, and then the alarm disappears.
- Check the alarm history, which includes all alarm events.
- Check the capability of alarm retrieval filter. Change the setting and retrieve.
- Check the colors for different level alarm events.
- Print alarm report.

SECURITY MANAGEMENT

- Connect the TNMS system with the management interface of SDH equipment by using Ethernet cable.
- Ensure the SDH equipment is working.
- Login as Administrator
- Add a user and define the user profile.
- Login as user and verify that user is able to perform various tasks as per profile.

LCT FUNCTIONALITY TEST

- Connect the LCT to the SDH equipment through LCT interface.
- Ensure the SDH equipment is working.
- Login the LCT.
- Change some configurations of the equipment.
- Get the fault information from the SDH equipment.

5.0 TEST RESULT

Sr. No.	Test Description	Results (OK / Not OK)
1.0	CONFIGURATION MANAGEMENT	
1.1	Capability to establish and maintain the backbone topology.	
1.2	Capability to provide graphical maps depicting the sub-rack configurations.	
1.3	Capability to plan, establish and change the static equipment configuration.	
1.4	Verification testing to support new equipment installation.	
1.5	Cross-connect capability between any of the two ports in same or different card.	
2.0	FAULT MANAGEMENT	
2.1	After generating an alarm, it is automatically displayed.	
2.2	Alarm has been shown automatically when there is card failure.	
2.3	NMS can maintain an alarm summary of unacknowledged current alarm.	
2.4	NMS can maintain an alarm history.	
2.5	Operator can acknowledge and clear alarms.	
2.6	Alarm retrieval filter is available.	
2.7	Alarms can be classified and configured as critical alarms, major alarms and minor alarms, in different colors.	
2.8	Alarm reports can be extracted.	
3.0	SECURITY MANAGEMENT	
3.1	Security Management functionality allows user addition and user profile definition.	
4.0	LCT Functionality Test	
4.1	LCT can get fault information from the connected SDH node.	
4.2	LCT is able to change the configuration of the connected SDH node.	
4.3	LCT is able to check for remote loopback & local loopback	
4.4	LCT can get fault/alarm information from the unconnected NE.	
4.5	LCT can get performance data from the unconnected NE.	

Status

() Tested – OK _____

() Tested – Failed _____

Remarks

Tested By : _____ Witnessed By : _____
(Manufacturer) (POWERGRID)

Date : _____ Date : _____

TPS-FOTS-018: 150, 175, 200, 225, 250 Km Link Optical Amplifier Test

Equipment Under Test : **Optical Amplifiers**

Test Parameters : **Output Power level of optical amplifier**

1.0 TEST DESCRIPTION

This test is performed to ensure the proper functionality of the Amplifier used for 150 km, 175 km, 200km, 225 km and 250 km link length and to measure of output power of amplifier.

2.0 TEST EQUIPMENT

- Optical Power Meter
- Low loss Optical Patch chord

3.0 TEST SETUP

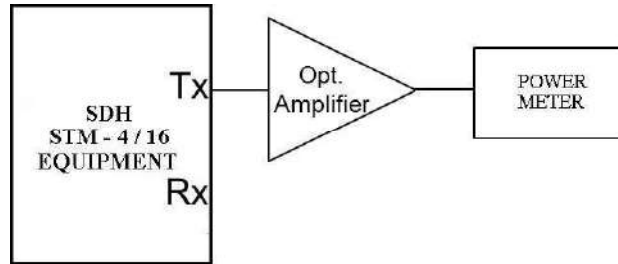

4.0 TEST PROCEDURE:

The test procedures are as follows:

- Make the test setup as shown in above figure.
- Connect the output port of amplifier to the optical power meter and switch on the equipment.
- Record the result showing on the optical power meter.

5.0 TEST RESULT

Sl.No.	Amplifiers as per approved BOQ	Result*
1	The optical output power	

*As per approved DRS.

Status

() Tested – OK _____

() Tested – Failed _____

Remarks

Tested By	:	_____	Witnessed By	:	_____
		(Manufacturer)			(POWERGRID)/Constituent
Date	:	_____	Date	:	_____

TPS-FOTS-019: Pre-Amplifier Receiver Sensitivity Measurement

Equipment Under Test : **Optical Pre-Amplifiers**

Test Parameters : **Receiver sensitivity level in dBm of Pre-Amplifier**

1.0 TEST DESCRIPTION

This test is performed to ensure the proper functionality of the Pre-Amplifier and to measure of receiver sensitivity of Pre-Amplifier.

2.0 TEST EQUIPMENT

- SDH Analyzer
- Optical Power Meter
- Variable Optical Attenuator
- Fixed Optical Attenuators
- Low loss optical patch cords

3.0 TEST SETUP

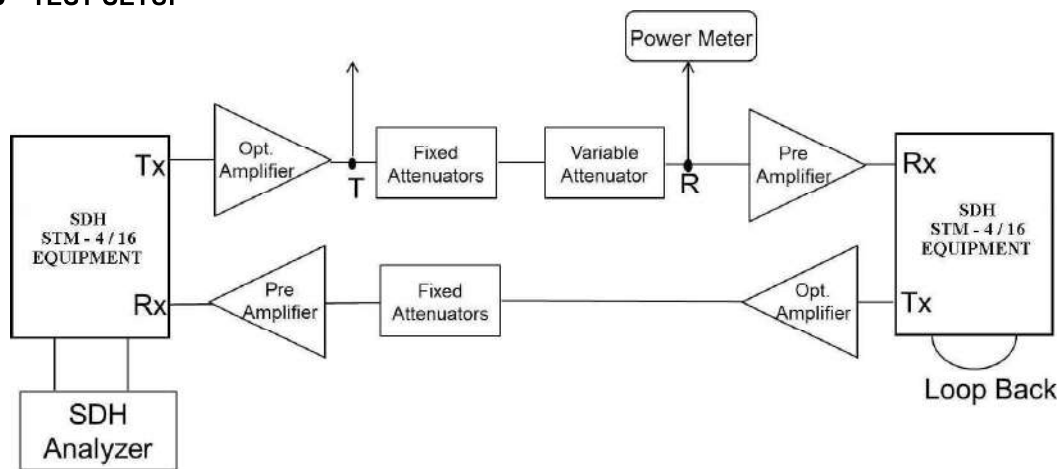

4.0 TEST PROCEDURE:

The test procedures are as follows:

- Make the test setup as shown in above figure.
- Set the SDH analyzer for BER testing at STM-4/16 level.
- Increase the attenuation by the variable attenuator till any error occurs at the tested optical interface card.
- Decrease the attenuation gradually, so that the error just goes off.

- Disconnect the optical patch cord from the R port and connect to the optical power meter, record the result showing on the optical power meter.

5.0 TEST RESULT

Sr.No.	Test Description	Actual Value (dBm)*
1	The receiver sensitivity of Pre-Amplifier.	The measured receiver sensitivity should be as per approved DRS

Status

() Tested – OK _____

() Tested – Failed _____

Remarks

Tested By _____ : _____
 (Manufacturer)

Witnessed By _____ : _____
 (POWERGRID)/Constituent

Date _____ : _____

Date _____ : _____

TPS-FOTS-020: Power Supply Range Measurement of Optical Amplifiers

Equipment Under Test : **Optical Amplifiers & Pre-Amplifiers**

Test Parameters : **Power supply range of Optical Amplifier & Pre-Amplifier.**

1.0 TEST DESCRIPTION

This test is performed to ensure the proper functionality of the optical amplifier & Pre-Amplifier for power supply voltage range of -40 to -60 VDC.

2.0 TEST EQUIPMENT

- SDH Analyzer
- Optical Power Meter
- Variable Optical Attenuator
- Fixed Optical Attenuators
- Low loss optical patch cords
- Variable Power Supply

3.0 TEST SETUP

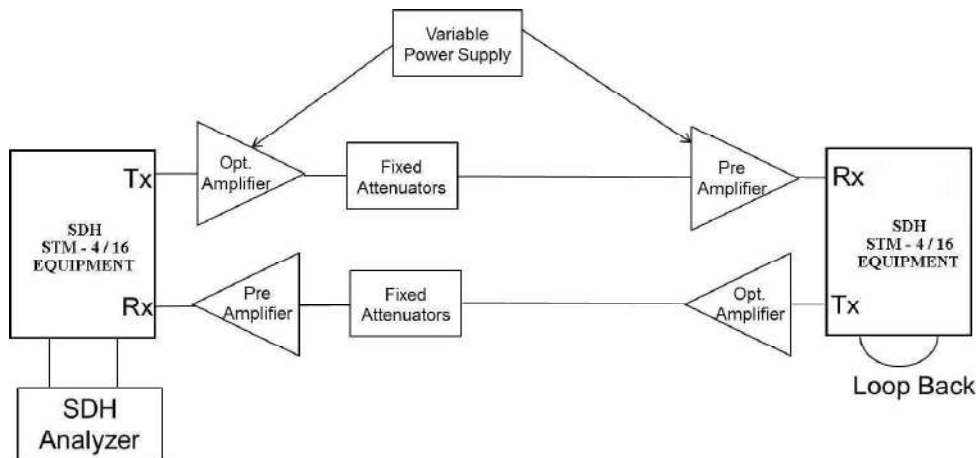

4.0 TEST PROCEDURE:

The test procedures are as follows:

- Set the SDH analyzer for BER testing at STM-4/16 level.

- Connect the variable power supply to the optical amplifier and set the output voltage of variable power supply to -40 VDC and run the BER test for 90 min.
- Vary the power supply voltage of optical amplifier from -40 VDC to -60 VDC using variable power supply and run the BER test for 90 min.
- Repeat the above steps with pre-amplifier also. The system should guarantee the performance at BER 10E-10

5.0 TEST RESULT

Sr.No.	Test Description	Result
1	Optical Amplifier Voltage @ -40 VDC	
2	Optical Amplifier Voltage @ -60 VDC	
3	Pre-Amplifier Voltage @ -40 VDC	
4	Pre-Amplifier Voltage @ -60 VDC	

Status

() Tested – OK _____

() Tested – Failed _____

Remarks

Tested By : _____ Witnessed By : _____
 (Manufacturer) (POWERGRID)/Constituent

Date : _____ Date : _____

TPS-FOTS-021: Electrical Interface Test

Equipment Under Test : **SDH Equipment**

Test Parameters : **Pulse Mask Test and Cable Compensation Test.**

1.0 TEST DESCRIPTION

- The aim of this test is to check if the shape of 2Mbit/s pulse (of E1 signal) is as per the specifications and performance of 2Mbps tributary by introducing desired attenuation. In this test the shape of an E1 pulse is compared with a standard a G.703 pulse mask using SDH Analyzer.

2.0 TEST EQUIPMENT

- SDH Analyzer
- Fixed Optical Attenuators
- Low loss optical patch cords
- Local Craft Terminal

3.0 TEST SETUP

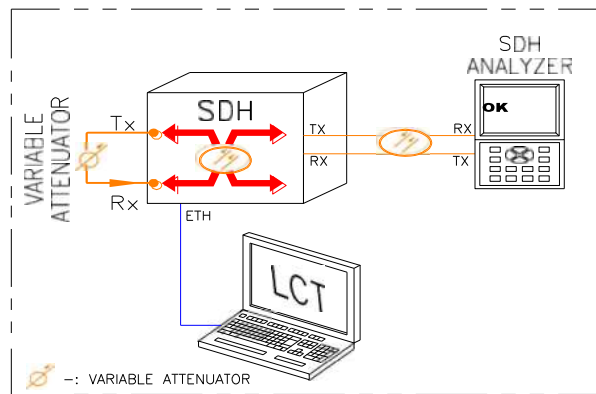

4.0 TEST PROCEDURE:

The test procedures are as follows:

Pulse Mask Test

- Make the test set up as shown in the diagram
- Enable (Admin Up) on E1 tributary for which pulse shape is to be measured, using NMS.
- Set the SDH Analyzer in E1 Pulse Shape mode.
- Observe the pulse shape, record the results and verify if the results are within the specification limits.
- Repeat the test for other tributaries

Cable Compensation Test

- Make the test set up as shown in the diagram
- Set the SDH Analyzer Tester in BER Test mode.
- Use 600 meter of RG59 coaxial cable to extend the Tx interface of the E1 to the SDH Analyzer.
- Introduce a Loop back on the optical interface using a fixed attenuator.
- The tester shall display OK sign, observe that the test runs error free for 120sec.
- Repeat the test for other tributaries

5.0 TEST RESULT

Trib · No.	Module	Slot No./ Port No.	TEST DESCRIPTION	SPECIFICATION	RESULTS
1			Pulse Mask/shape	As per G.703 spec	
2			Pulse Mask/shape	As per G.703 spec	
3			Cable Compensation	As per G.703 spec	
4			Cable Compensation	As per G.703 spec	

Status

() Tested – OK _____

() Tested – Failed _____

Remarks

Tested By _____ : _____ Witnessed By _____ : _____

(Manufacturer)

(POWERGRID)/Constituent

Date _____ : _____ Date _____ : _____

TPS-FOTS-022: Generation of Bit Error Curve

Equipment Under Test : **SDH Equipment**

Test Parameters : **Bit Error Curve**

1.0 TEST DESCRIPTION

To plot a BER curve of optical interface by varying the input optical power levels and noting signal degradation values.

2.0 TEST EQUIPMENT

- SDH Analyzer
- Fixed Optical Attenuators
- Optical Variable Attenuator
- Low loss optical patch cords
- Local Craft Terminal

3.0 TEST SETUP

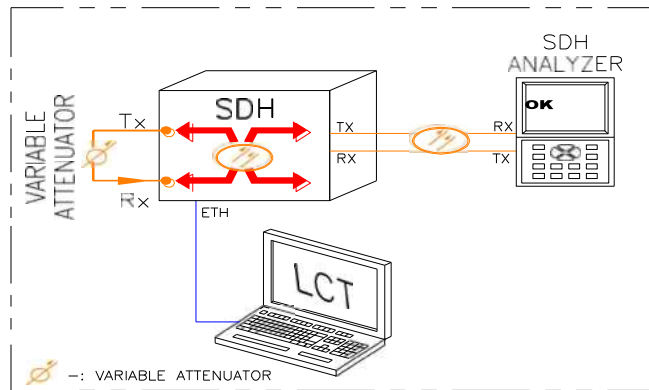

4.0 TEST PROCEDURE:

The test procedures are as follows:

- The test set-up will be as indicated in above figure.
- Create a cross connection to terminating E1 from one of the optical port
- Apply loop on the optical port using fixed attenuator.
- Connect the SDH Analyzer to the configured E1 of the 2M tributary card.
- Measure BER by gradually increasing the attenuation value and check the optical power at different BER values between $10E^{-10}$ and $10E^{-6}$
- Record the results and repeat the test for different optical port.

5.0 TEST RESULT

Trib · No.	Module	Slot No./ Port No./Sr no	Optical Input Power (dBm) at BER				RESULTS
			10E ⁻⁹	10E ⁻⁸	10E ⁻⁷	10E ⁻⁶	
1							
2							
3							
4							

Status

() Tested – OK _____
 () Tested – Failed _____

Remarks

Tested By _____ : _____ Witnessed By _____ : _____
 (Manufacturer) (POWERGRID)/Constituent
 Date _____ : _____ Date _____ : _____

TPS-FOTS-023: Test for Spare Cards and Spare Slots

Equipment Under Test : **SDH Equipment**

Test Parameters : **Test for Spare Cards and Spare Slots**

1.0 TEST DESCRIPTION

This test is performed to ensure the proper functionality of the blank slots in the SDH node and functionality of the spare cards supplied.

2.0 TEST EQUIPMENT

- E1 Datacom Tester
- Optical Power Meter
- SDH Analyzer
- Ethernet Tester
- Local Craft Terminal

3.0 TEST PROCEDURE:

The test procedures are as follows:

- In order to test the spare slot in the SDH node, eject the working card from the configured slot and insert it in one of the blank slot.
- Re-configure the newly inserted cards as per the initial configuration and test the functionality.
- Refer Test Procedures for receiver Sensitivity, Optical Output power, E1 BER TEST & Ethernet parameter test and check the functionality.
- In order to test the spare supplied, replace the working card with the spare card and test the functionality.
- Tabulate the results

4.0 TEST RESULT

Sr No.	Station Name	Blank Slot	Card Type	Configuration Status (OK / NOT OK)
4.1		Slot__		
4.2		Slot__		
4.3		Slot__		
4.4		Slot__		

Sr No.	Station Name	Spare Card model	Test Slot	Functionality Status (OK / NOT OK)
4.5			Slot__	
4.6			Slot__	
4.7			Slot__	
4.8			Slot__	

Status

() Tested – OK _____

() Tested – Failed _____

Remarks

Tested By _____ : _____ Witnessed By _____ : _____
 (Manufacturer) (POWERGRID)/Constituent

Date _____ : _____ Date _____ : _____

TPS-FOTS-024: Random Inspection to verify the Accuracy of Documents

Equipment Under Test : **SDH Equipment**

Test Parameters : **Verify the Documents and Drawings.**

1.0 TEST DESCRIPTION

To conduct additional tests to verify the accuracy of the product documentation i.e. Brochures, DRS. One or two parameters shall be chosen from the list of Parameters in Data sheet and tests shall be conducted to verify the same.

2.0 TEST EQUIPMENT

- As required by the Test Procedure.

3.0 TEST PROCEDURE:

The procedures followed to test the parameters / functionality shall be enclosed with the FAT report.

4.0 TEST RESULT

The test results shall confirm with the data sheet.

Status

() Tested – OK _____

() Tested – Failed _____

Remarks

Tested By : _____ Witnessed By : _____
(Manufacturer) (POWERGRID)/Constituent

Date : _____ Date : _____

TPS-FOTS-025: Cable Compensation on Ethernet Interface

Equipment Under Test : **Ethernet Card of SDH Equipment**

Test Parameters : **Cable Compensation (Attenuation) Test.**

1.0 TEST DESCRIPTION

The aim of this test is to verify that the Ethernet interface functions error free until the maximum allowable cable length.

2.0 TEST EQUIPMENT

- Ethernet Tester
- Local Craft Terminal

3.0 TEST SETUP

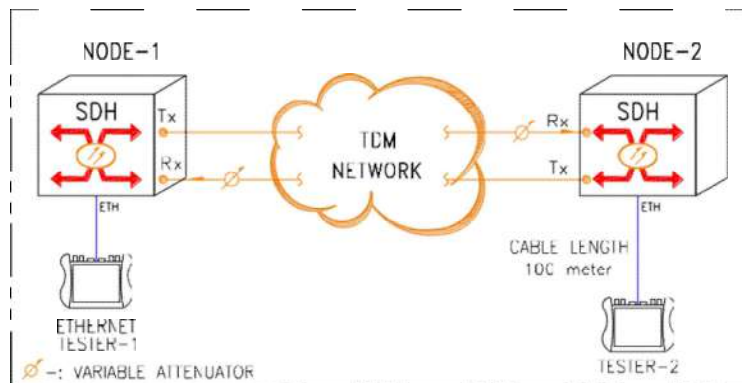

4.0 TEST PROCEDURE:

The test procedures are as follows:

- Connect the two (2) SDH nodes (Node-1 & 2) with optical patch cords as shown in above figure.
- Connect one Ethernet Analyzer to the configured LAN port of Node-1 in loopback mode.
- Connect another Ethernet Analyzer in terminal mode to the configured LAN port of Node-2 using 100 meters of LAN cable.
- Set the LAN ports of both the nodes on “100M full duplex” mode.
- Verify that the Ethernet link test runs without any error and record the test results.

5.0 TEST RESULT

Sr No.	Station Name	Slot \ Port No.\Sr. No.	Ethernet link functionality @ 100 meter.	Remarks

4.1				
4.2				
4.3				
4.4				

Status

() Tested – OK _____

() Tested – Failed _____

Remarks

Tested By _____ : _____ Witnessed By _____ : _____

(Manufacturer)

(POWERGRID)/Constituent

Date _____ : _____ Date _____ : _____

TPS-FOTS-026: Spectral Characteristics & Central Wavelength (Optical Interface)

Equipment Under Test : **SDH Equipment**

Test Parameters : **Optical Spectrum and Center Wavelength**

1.0 TEST DESCRIPTION

This purpose of this test is to measure the Spectral line width (-20 dB / RMS level) & Output Central Wavelength of the Optical Interfaces is as per specification.

2.0 TEST EQUIPMENT

- Optical spectrum analyzer
- Optical power meter
- Optical Patch Chords
- LCT/NMS

3.0 TEST SETUP

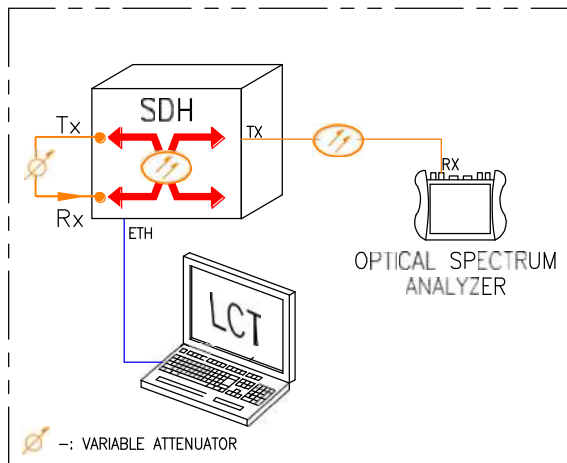

4.0 TEST PROCEDURE:

The test procedure is as follows:

- Make the test setup as shown in above figure.
- Connect the Tx port of the Optical Interface to be tested to the Optical Spectrum Analyzer.
- Enable the admin status of the (STM-16/4) optical port to be tested by using LCT/NMS.
- Measure the optical spectrum of the (STM-16/4) optical transmitters using optical spectrum analyzer.
- Tabulate the results
- Measure the Centre Wavelength of the (STM-16/4) optical transmitters using optical spectrum analyzer.

- Tabulate the results

5.0 TEST RESULT

Optical Spectrum

Sr. No.	Module	Slot / Port	Specification		Result in dBm
			-20 db	RMS	

*Optical spectrum measurements shall be as per G.957 Standard

Output Centre Wavelength

Sr. No.	Module	Slot / Port	Central Wavelength (In dBm) (OK / NOT OK)

*Optical spectrum measurements shall be as per G.957 Standard

Status

() Tested – OK _____
 () Tested – Failed _____

Remarks

Tested By _____ : _____ Witnessed By _____ : _____
 (Manufacturer) (POWERGRID)/Constituent
 Date _____ : _____ Date _____ : _____

TPS-FOTS-027: Data Channel Testing

Equipment Under Test : **SDH Equipment**

Test Parameters : **Testing of Data Channel**

1.0 TEST DESCRIPTION

This purpose of this test is to verify user data channel available on SDH Equipment

2.0 TEST EQUIPMENT

- Laptop
- Optical Patch Chords

3.0 TEST SETUP

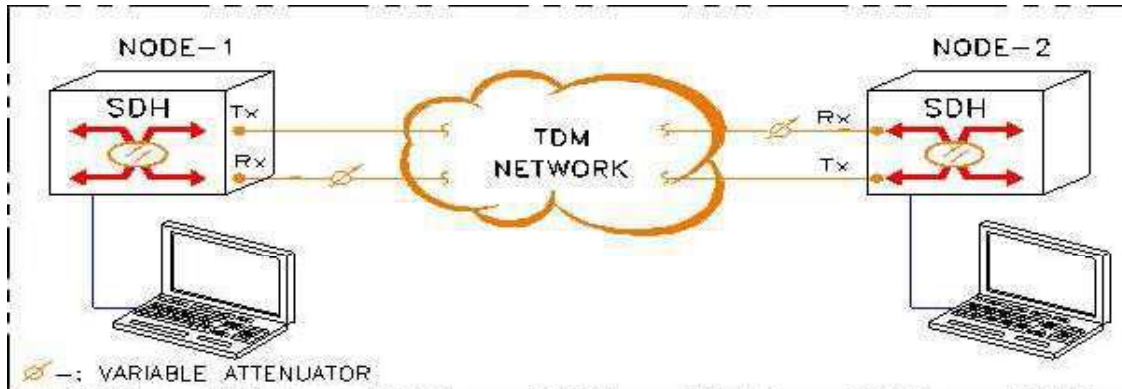

4.0 TEST PROCEDURE:

The test procedure is as follows:

- Make the test setup as shown in above figure.
- Connect the laptop to data channels at both the nodes.
- Run the ping test to check the data channel.

5.0 TEST RESULT

Both laptops ping each other thro data channel

Status

() Tested – OK _____

() Tested – Failed _____

Remarks

SITE ACCEPTANCE TEST PROCEDURE
(FO Transmission system & associated NMS System)

Contents

1.	SCOPE OF TESTING	4
2.	TEST PROCEDURES	7
3.	Test Equipment.....	9
4.	SAT Procedure.....	10
4.1	SAT-I.....	10
	TPS-01 : Physical Inspection for conformance to drawings, rack elevations and appearance of equipment and cabling	10
	TPS-02 : Station power supply input and equipment power supply(DC-DC converter) output voltage measurements	13
	TPS-03: Terminal transceiver performance testing (Tx power, Receive signal strength).....	15
	TPS-04: Services Channel performance Test.....	18
	TPS-05: Craftsperson interface, alarm and control functional performance.....	19
	TPS-06: Rack and local alarms.....	21
	TPS-07: Network management interface and supervision performance	23
	TPS-08: Correct configuration, level setting & adjustments and termination of Input/ output interfaces	25
	TPS-09: Proper establishment of Safety and signalling earthing system and resistance to ground to be checked.	26
	TPS-10: Simulation of failure conditions and failover of protected components.	27
	TPS-11: Craftsperson interface, alarm and control functional performance.....	29
	TPS-12: Physical inspection for conformance to drawings, rack elevations and appearance of equipment and cabling of NMS System Workstation hardware inventory, configuration and characteristics of NMS System	31
	TPS-13: Demonstration of proper operation of all hardware, including workstations peripherals of NMS System....	33
4.2	SAT-II.....	34
	TPS-14: Ethernet Channel Testing (SDH).....	34
	TPS-15: Measurement of BER For SDH Link.....	37

TPS-16: Delay measurement..... 38

4.3 SAT-III 39

TPS-17: End to End testing of Voice circuits..... 39

TPS-18: Testing of NMS Functionality 40

TPS-19: Protection Switching and Synchronization of Equipment 41

TPS-20: End to End Data Channel testing..... 45

TPS-21: Interfacing with Existing Communication System 48

TPS-22: Testing of integration of supplied NMS/NE with regional UNMS/OSS (if available) 50

**TPS-23: Comprehensive Cyber Security Tests in compliance to latest cyber security guidelines issued by CEA/MoP
or any other govt department..... 51**

1. SCOPE OF TESTING

All equipment shall be tested on site under the conditions in which it will normally operate. The tests shall be exhaustive and shall demonstrate that the overall performance of the contract works satisfies every requirement specified.

Phases of Site Acceptance Testing

1.1 Installation Testing

Site Installation Test

The field installation test will be performed for all equipment at each site.

The purpose of installation test is to ensure that all the equipments and cables conform to the BOQ; the installation of equipment and cabling conform to drawings, rack elevations; the appearance of equipment meets the requirements.

(1) Installation tests on FO Transmission system (SDH Equipments) :

The installation tests on FO Transmission system (SDH Equipments) mainly include:

1.	Physical Inspection for conformance to drawings, rack elevations and appearance of equipment and cabling
2.	Station power supply input and equipment power supply (DC-DC converter) output voltage measurements
3.	Terminal transceiver performance testing (Tx power, Tx spectrum, receive signal strength, connector losses etc.)
4.	Service channel performance
5.	Craftsperson interface, alarm , control functional performance
6.	Rack and local alarms: No alarms shall be present and all alarms shall be demonstrated to be functional
7.	Network management interface and supervision performance
8.	Correct configuration, level setting & adjustments and termination of Input/ output interfaces
9.	Proper establishment of Safety and signalling earthing system and resistance to ground to be checked.
10.	Simulation of failure conditions and failover of protected components.

(2) Installation Test on NMS system.

The installation tests on NMS system mainly includes:

1.	Physical inspection for conformance to drawings, rack elevations and appearance of equipment and cabling.
2.	Workstation (Remote & Local) hardware inventory, configuration and characteristics.
3.	Demonstration of proper operation of all hardware, including workstations (Remote & Local) peripherals.

1.2 Link Commissioning Testing

The link commissioning tests shall verify that communication can be performed over the fiber optic link under test. Delay measurement, Bit Error measurements & service channel performance monitoring shall be made on the fibre optic links to verify compliance with designed link performance.

For Ethernet interface: At a minimum the following test requirements shall be demonstrated as per RFC 2544:

- a) Ping test
- b) Throughput test
- c) Latency test
- d) Packet Loss

10% of the total links (as chosen by PGCIL/Constituent, generally to cover links from all configurations used) shall be tested for duration of 12 Hours.

Rest of the links shall be tested for 1 Hour. In case a link does not meet the performance requirements during 1 hour, then the duration of the test shall be increased to 12 hours.

In case any link does not meet the performance requirements during 12 hour, then the cause of failure shall be investigated and the test shall be repeated after rectifying the defects.

This phase of testing shall be conducted by the Contractor and witnessed by the Employer. Field adjustments shall be made to meet established standard, however if the field adjustments fail to correct the defects the equipments may be returned to the Contractor for replacement at his own expense. In case any adjustments are required to be made during the interval of the test then the test shall be repeated.

1.3 Integrated Testing

Prior to commencement of integrated testing the overall system shall be configured as required to provide all the data and voice channel required to interconnect the various control centres and RTU. The integrated testing shall include end-to-end testing of back-bone network. Integrated testing for last batch shall include testing of the entire back-bone network. The intent of integrated testing is to demonstrate that the equipment is operational end to end under actual conditions, that all variances identified during factory and field installation and communications testing have been corrected, and that the communication equipment is compatible with other equipment at all locations. The Integrated System Test shall include all fibre optic transmission equipment, termination equipment, the network management subsystem and other components.

At a minimum the following tests shall be included in the integrated testing:

- 1.3.1 Installation testing for NMS as per table given below
- 1.3.2 Equipment configuration shall be checked to establish that it supports the channel routing.
- 1.3.3 End to end testing of all individual voice circuits originating from PLCC, PABX or Phones and to establish proper interfacing with PLCC\PABX\Phones and to demonstrate proper operation of channels over wideband systems. Operation shall be checked in terms of quality of voice, call initiation and call termination processes.
- 1.3.4 End-to-end testing of all individual Data Circuits originating from PLCC, RTU and SCADA Front Ends and to establish proper interfacing with PLCC\RTU\Front End and to demonstrate proper operation of channels over wideband systems. Operation shall be checked in terms of monitoring of BER/packet loss.
- 1.3.5 Testing of NMS to demonstrate proper operation of all functions: Configuration Management, Performance Management, Fault, Management and Security management. All the standard features of the NMS shall be demonstrated for proper functioning.
- 1.3.6 Demonstration of Protection switching including ring network whereas applicable and synchronization of equipment as per synchronization plan.

2. TEST PROCEDURES

2.1 Installation Testing

Following is the list of Installation and Link Commissioning tests to be conducted on the selected equipment during the Site acceptance testing: -

Sr. No	Test Description	Test Procedure No.
1	Physical Inspection for conformance to drawings, rack elevations and appearance of equipment and cabling	TPS-01
2	Station power supply input and equipment power supply (DC-DC converter) output voltage measurements	TPS-02
3	Terminal transceiver performance testing (Tx power, Tx spectrum, receive signal strength, connector losses etc.)	TPS-03
4	Services channel performance Test	TPS-04
5	Craftsperson interface, alarm and control functional performance	TPS-05
6	Rack and local alarms	TPS-06
7	Network management interface and supervision performance	TPS-07
8	Correct configuration, level setting & adjustments and termination of Input/ output interfaces	TPS-08
9	Proper establishment of Safety and signalling earthing system and resistance to ground to be checked.	TPS-09
10	Simulation of failure conditions and failover of protected components.	TPS-10
11	Craftsperson interface, alarm and control functional performance (PDH)	TPS-11
12	Physical inspection for conformance to drawings, rack elevations and appearance of equipment and cabling of NMS System Workstation hardware inventory, configuration and characteristics of NMS System	TPS-12
13	Demonstration of proper operation of all hardware, including workstations peripherals of NMS System	TPS-13

2.2 Link Commissioning Testing

The commissioning tests shall verify that communication can be performed over the fiber optic link under test. Delay measurement, Bit Error measurements & service channel performance monitoring shall be made on the fibre optic links to verify compliance with designed link performance.

For Ethernet interface: At a minimum the following test requirements shall be demonstrated as per RFC 2544:

- 2.2.1 Ping test
- 2.2.2 Throughput test
- 2.2.3 Latency test
- 2.2.4 Packet Loss

10% of the total links (Chosen by PGCIL, generally to cover links from all configurations used) shall be tested for duration of 12 Hours.

Rest of the links shall be tested for 1 Hour. In case a link does not meet the performance requirements during 1 hour, then the duration of the test shall be increased to 12 hours.

In case any link does not meet the performance requirements during 12 hour, then the cause of failure shall be investigated and the test shall be repeated after rectifying the defects.

This phase of testing shall be conducted by the Contractor and witnessed by the Employer. Field adjustments shall be made to meet established standard, however if the field adjustments fail to correct the defects the equipments may be returned to the Contractor for replacement at his own expense. In case any adjustments are required to be made during the interval of the test then the test shall be repeated.

Sr. No	Test Description	Test Procedure No.
1	Ethernet Channel Testing	TPS-14
2	Measurement of BER For SDH Link	TPS-15
3	Delay measurement	TPS-16

2.3 Integrated Testing

Following is the list of Integrated testing tests to be conducted on the selected equipment during the Site acceptance testing: -

Sr. No	Test Description	Test Procedure No.
1	End to End testing of Voice circuits	TPS-17
2	Testing of NMS Functionality	TPS-18
3	Protection Switching and Synchronization of Equipment	TPS-19
4	End to End Data Channel testing	TPS-20
5	Interfacing with Existing Communication System	TPS-21

3. Test Equipment

Prior to start of testing a consolidated list of all test equipment used for the Site Acceptance Testing shall be provided along with Make/Model numbers and valid Calibration Certificates.

Test Equipments/Instruments to be used during SAT :

- 1) E1 BER Tester
- 2) Ethernet Tester
- 3) Optical Power meter
- 4) Digital Multi meter
- 5) VF Tester
- 6) Earth Tester
- 7) Any other as per testing requirements

4. SAT Procedure

4.1 SAT-I

TPS-01 : Physical Inspection for conformance to drawings, rack elevations and appearance of equipment and cabling

Equipment Under Test : FO EQUIPMENTS (SDH)

Test Parameter : Physical Inspection for conformance to drawings, rack elevations and appearance of equipment and cabling

1. Test Descriptions

To identify correctly given equipment and verify the hardware configuration, and make the equipment ready for software configuration and commissioning.

2. Test Procedure

- Check the hardware configuration as per the configuration drawing.
- Check the installation whether it is as per the site layout drawing.
- Check the workmanship and accuracy of the installation and cabling.
- Check for physical damage
- Check the quantity as per approved BOQ.

3. Test Results Records

Test Parameters	Test Criteria	Test Results
Hardware configuration	Complies with the approved BOQ	Ok / Not Ok
Equipment layout	Equipment layout complies with the approved site layout drawing	Ok / Not Ok
Installation of Rack	<ul style="list-style-type: none">• Location should conform to layout drawing• Fixed on floor by bolts	Ok / Not Ok
Installation of subrack and card	<ul style="list-style-type: none">• Subrack should be firmly fixed• Cards should be inserted into the slots and locked	Ok / Not Ok
Cabling and terminator	<ul style="list-style-type: none">• DC Power cable colour	Ok / Not Ok

processing	<p>to distinguish the polarity</p> <ul style="list-style-type: none"> • Cable lays smoothly, straight and tidily, without obvious twist and cross. • Cable buffer arcs are consistent. • Well colligated • Stripped length of cable should be consistent. • Good connection. Soldering point should be smooth and tight 	
Physical damage	<ul style="list-style-type: none"> • Any physical damage in equipment 	Ok / Not Ok

Make the sketch drawing of actual telecom room layout if any variance.

4. Test Remarks

Equipment Under Test: _____

Test Date and Time: _____

Site Name: _____

Tested By : _____ **Witnessed By** : _____
(Manufacturer/Contractor) (POWERGRID/Constituent)

Date : _____ **Date** : _____

TPS-02 : Station power supply input and equipment power supply(DC-DC converter) output voltage measurements

Equipment Under Test : FO EQUIPENTS (SDH)

Test Parameter : Station power supply input and equipment power supply (DC-DC converter) output voltage measurements

1. Test Descriptions

To check the station Power Supply Voltage and the PDP output Voltage is with in the given range.

2. Test Procedure

- Check the i/p voltage at PDP.
- Check the o/p voltage at PDP.

3. Test Equipments Required

- Digital Multimeter

Test Results Records

Test Parameters	Test Criteria	Test Results
i/p Voltage at PDP	i/p voltage should be in the range of -42V to -55V	Ok / Not Ok
o/p Voltage at PDP	o/p voltage should be in the range of -42V to -55V	Ok / Not Ok

5. Test Remarks

Equipment Under Test: _____

Test Date and Time: _____

Site Name: _____

Tested By : _____ **Witnessed By** : _____
(Manufacturer/Contractor) (POWERGRID/Constituent)

Date : _____ **Date** : _____

TPS-03: Terminal transceiver performance testing (Tx power, Receive signal strength)

Equipment Under Test : FO EQUIPENTS (SDH)

Test Parameter : Terminal transceiver performance testing (Tx power, Receive signal strength)

1. Test Descriptions

To check the Tx Power, Receiving Signal Strength is within the given range.

2. Test Procedure

Tx Power Measurement

- Connect the output port (Tx) of the tested optical interface card to the optical power meter.
- Turning the optical power meter to the specified wavelength.
- Measure the Tx output power level in dBm.
- Record the result showing on the optical power meter.

Receiving Signal Strength

- Connect the output port (Rx) of the tested optical interface card to the optical power meter.
- Turning the optical power meter to the specified wavelength.
- Measure the Rx input power level in dBm.
- Record the result showing on the optical power meter.

3. Test Equipments Required

- Digital Optical Power Meter

4. Test Results Records

Tx Power Measurement:

Sr. No.	Node / Station	Sr.No.	Optical Interface Type (As per Approved BoQ)	Minimum (dBm)*	Maximum (dBm)*	Actual (dBm)
1						
2						

3						
4						

*As per Approved DRS

The measured optical output power should be within the limits as expressed in the table given above.

Receiving Signal Strength:

Sr. No.	Node / Station	Sr.No.	Module Type (As per Approved BoQ)	Receiver Signal Strength (dBm)*	Actual (dBm)
1					
2					
3					

The measured receiver power should be within the limits as expressed in the table given above.

* As per Approved DRS

5. Test Remarks

Equipment Under Test: _____

Test Date and Time: _____

Site Name: _____

Tested By : _____ **Witnessed By** : _____
(Manufacturer/Contractor) (POWERGRID/Constituent)

Date : _____ **Date** : _____

TPS-04: Services Channel performance Test

Equipment Under Test : FO EQUIPENTS (SDH)

Test Parameter : Services Channel performance Test

1. Test Descriptions

To identify correct operation of the services channels used for the EOW phones.

2. Test Procedure

- Connect the EOW phone to services channel.
- Make a call from EOW phone to any station at other end (as per EOW numbering plan)
- Check the quality of voice
- Make a Omnibus call to different sites and check

3. Test Results Records

EOW telephone works well, conversation quality is satisfactory.

Selective calling Ok / Nok

Omnibus calling Ok / Nok

4. Test Remarks

Equipment Under Test: _____

Test Date and Time: _____

Site Name: _____

Tested By : _____
(Manufacturer/Contractor)

Witnessed By : _____
(POWERGRID/Constituent)

Date : _____

Date : _____

TPS-05: Craftsperson interface, alarm and control functional performance

Equipment Under Test : FO EQUIPMENTS (SDH)

Test Parameter : Craftsperson interface, alarm and control functional performance

1. Test Descriptions

Functions of LCT:

Change configuration

Get alarm of any fault

Get performance information

To simulate defects by using the measurement equipment and LCT

Performance monitoring

Loopback

2. Test Equipments Required

- LCT
- BER Tester

3. Test Procedure

Connect the LCT to equipment under test through management port

- Ensure the equipment under test is working.
- Login the LCT.
- Change some configurations of the equipment,
- Get the fault information from the equipment.
- Get and browse the performance data of the equipment.
- Change configurations of another station indirectly, get its fault information and performance data.

Loop back test

- Apply a software loop on remote end E1 channel through LCT.
- Test the loop back with E1 tester on local end.
- Record the result there should be no error during this period.

4. Test Results Records

Test item	Ok / Not Ok
LCT is able to change the configuration of the connected NE.	
LCT can get fault information from the connected NE.	
LCT can get performance data from the connected NE.	
LCT is able to change the configuration of any NE in the network.	
LCT can get fault/alarm information from the unconnected NE.	
LCT can get performance data from the unconnected NE.	
Check for connection of NMS and LCT on the network at the same time	
Check for remote loopback, local loopback	
Check for cross connection	
Test the loop back with E1 tester on local end	
Record the result there should be no error during this period	

Alarms should be indicated on LCT and equipment when there is some failure. Equipment can be configured by LCT.
 Performance data can be monitored on LCT.

5. Test Remarks

Equipment Under Test: _____

Test Date and Time: _____

Site Name: _____

Tested By : _____ **Witnessed By** : _____
 (Manufacturer/Contractor) (POWERGRID/Constituent)

Date : _____ **Date** : _____

TPS-06: Rack and local alarms

Equipment Under Test : FO EQUIPENTS (SDH)
Test Parameter : Rack and local alarms: No alarms shall be present and all alarms shall be demonstrated to be functional

1. Test Descriptions

To check the Rack alarm and Local alarms are correctly reflects on Equipment and LCT.

Rack Alarm

- Urgent Alarm's
- Non Urgent alarm's
- No Alarm

Local Alarms on LCT FO System

- LOS on optical port
- LOS on 2Mbit/s Port
- Card failure by pulling out some cards

2. Test Equipments Required

- LCT

3. Test Procedure

Rack Alarm

- 1) Disconnect one of the optical Rx port. There should be Urgent alarm of SDH Sub-Rack.
- 2) Restore the optical RX port, then there should be no alarm on SDH Sub-Rack
- 3) Remove the 2Mbps cable from the DDF (Should be working 2M), there should be Urgent alarm on SDH Sub-Rack.
- 4) Connect the 2Mbps cable on DDF, the Urgent alarm should be cleared.

TPS-07: Network management interface and supervision performance

Equipment Under Test : FO EQUIPMENTS (SDH)

Test Parameter : Network management interface and supervision performance

1. Test Descriptions

To check the Communication between NMS and Gateway NE through management interface.

Test will be carried out to check the following parameters

- Configuration
- Loopback Testing
- Laser Testing
- Alarm reporting
- Performance monitoring

2. Test Equipments Required

- NMS System
- BER Tester

3. Test Procedure

- Login to the equipment through management port.
- STM-4 /16/64 Line loop back in software
- E1 Loop back in software and check on BER tester
- Laser switch off/on through software
- Monitor optical power
- Display of alarms
- Performance event collection like ES, SES, BBE for 15Min

4. Test Results Records

Verify all the above listed test procedures is working ok:	:	Ok / Not Ok
NMS can configure and supervise the whole network	:	Ok/ Not Ok
Diagnostics is possible on NMS	:	Ok / Not Ok
Alarms should be displayed if there is any failure	:	Ok / Not Ok

5. Test Remarks

Equipment Under Test: _____

Test Date and Time: _____

Site Name: _____

Tested By : _____ **Witnessed By** : _____
(Manufacturer/Contractor) (POWERGRID/Constituent)

Date : _____ **Date** : _____

TPS-08: Correct configuration, level setting & adjustments and termination of Input/ output interfaces

Equipment Under Test : FO EQUIPMENTS (SDH)

Test Parameter : Correct configuration, level setting & adjustments and termination of Input/ output interfaces

1. Test Descriptions

To check the Equipment configuration is according to approved Configuration plan. To check the Input/output termination of Optical and Electrical cables are according to approved scheme

2. Test Equipments Required

- LCT
- Approved Optical and 2Mbps distribution Diagrams

3. Test Procedure

- Connect the LCT to the SDH equipment through f interface.
- Ensure the SDH equipment is working.
- Login the LCT.
- Check the equipment configuration
- Check the Termination of Input and Output cables.
- Check different level settings in the SDH Equipment.

4. Test Results Records

Configuration, level setting adjustment and termination should comply with the approved documents : Ok / Not Ok

5. Test Remarks

Equipment Under Test: _____

Test Date and Time: _____

Site Name: _____

Tested By : _____ Witnessed By : _____
(Manufacturer/Contractor) (POWERGRID/Constituent)

Date : _____ Date : _____

TPS-09: Proper establishment of Safety and signalling earthing system and resistance to ground to be checked.

Equipment Under Test : FO EQUIPMENTS (SDH)

Test Parameter : Proper establishment of Safety and signalling earthing system and resistance to ground to be checked

1. Test Descriptions

To check the Earthing cable Terminations To check the Earth resistance.

2. Test Equipments Required

- Clamp Earth Tester

3. Test Procedure

- Check that all the earthing connection are terminated on the earth bus bar are tightened
- All equipments are connected with Earth bus bar
- Colour of the Earth cable is yellow-green or green
- Measure the Earth resistance Clamp Earth Tester
- Check the wrist strap is available at each station

4. Test Results Records

Earthing connections are properly done : Ok / Not Ok
Earth resistance measured is less than 10 Ω : Ok/ Not Ok

5. Test Remarks

Equipment Under Test: _____

Test Date and Time: _____

Site Name: _____

Tested By : _____
(Manufacturer/Contractor)

Witnessed By : _____
(POWERGRID/Constituent)

Date : _____

Date : _____

TPS-10: Simulation of failure conditions and failover of protected components.

Equipment Under Test : FO EQUIPMENTS (SDH)

Test Parameter : Simulation of failure conditions and failover of protected components.

1. Test Descriptions

To check the Failure conditions and protection components for following cards :

- Control Cards
- Optical Cards

2. Test Equipments Required

- BER Tester

3. Test Procedure

Control Card

- Control cards work on 1+1 protection. 1 protection card for 1 workingcard.
- Make the equipment work on normal status.
- Pull out the working Control card.
- The protection Control card should take over, and traffic should be restored.

Optical Card

- Optical cards work on 1+1 protection. 1 protection card for 1 workingcard.
- Make the equipment work on normal status.
- Pull out the working Optical card.
- The protection STM-4 /16 card should take over, and traffic should be restored.

For both the cards make software loop on any E1 and put in the BER testing mode. Check that during both the test the traffic is restored automatically.

4. Test Results Records

Traffic restored automatically even if one
Control card and Optical card terms Faulty : Ok / Not Ok

5. Test Remarks

Equipment Under Test: _____

Test Date and Time: _____

Site Name: _____

Tested By : _____ **Witnessed By** : _____
(Manufacturer/Contractor) (POWERGRID/Constituent)

Date : _____ **Date** : _____

TPS-11: Craftsperson interface, alarm and control functional performance

Equipment Under Test : TERMINATION EQUIPMENT SUB-SYSTEM

Test Parameter : Craftsperson interface, alarm and control functional

1. Test Descriptions

Functions of LCT:

Change configuration

Get alarm of any fault

Get performance information

To simulate defects by using the measurement equipment and LCT

Performance monitoring

Loopback

2. Test Equipments Required

- LCT
- BER Tester

3. Test Procedure

Connect the PDH Equipment with LCT.

- Connect the LCT to the PDH equipment
- Ensure the PDH equipment is working.
- Login the LCT.
- Change some configurations of the equipment,
- Get the fault information from the PDH equipment.
- Get and browse the performance data of the equipment.
- Change configurations of another station indirectly, get its fault information and performance data.

Loop back test

- Apply a software loop on any E1 channel thro LCT
- Test the loop back with E1 tester

4. Test Results Records

Test item	Ok / Not Ok
LCT is able to change the configuration of the connected NE.	
LCT can get fault information from the connected NE.	
LCT can get performance data from the connected NE.	
LCT is able to change the configuration of any NE in the network.	
Check for remote loopback, local loopback	
Check for branching connection	

Alarms should be indicated on LCT and equipment when there is some failure.
 Equipment can be configured by LCT.
 Performance data can be monitored on LCT

5. Test Remarks

Equipment Under Test: _____

Test Date and Time: _____

Site Name: _____

Tested By : _____ **Witnessed By** : _____

(Manufacturer/Contractor)

(POWERGRID/Constituent)

Date : _____ **Date** : _____

TPS-12: Physical inspection for conformance to drawings, rack elevations and appearance of equipment and cabling of NMS System Workstation hardware inventory, configuration and characteristics of NMS System

Equipment Under Test : NMS System
(incl. all associated HW & SW supplied with the complete system)

Test Parameter : Physical Inspection for conformance to drawings, rack elevations and appearance of equipment and cabling Hardware & Software Inventory, Configuration and characteristic

1. Test Descriptions

To identify correctly given equipment and verify the hardware configuration, and make the equipment ready for software configuration and commissioning.

2. Test Procedure

- Check the hardware configuration as per the configuration drawing.
- Check the installation whether it is as per the site layout drawing.
- Check the workmanship and accuracy of the installation and cabling.
- Check for physical damage
- Check the Hardware & software inventory as per approved DRS & BOQ documents.

3. Test Results Records

Make the sketch drawing of actual NMS room layout if any variance.



No Physical Damage	: Ok / Not Ok
Hardware & Software Inventory as per approved DRS & BOQ	: Ok / Not Ok
Hardware Configuration as per approved DRS & BoQ	: Ok / Not Ok

TPS-13: Demonstration of proper operation of all hardware, including workstations peripherals of NMS System

Equipment Under Test : NMS System

Test Parameter : Demonstration of proper operation of all hardware, including workstations peripherals of NMS System

1. Test Descriptions

To identify all the hardware including Workstations and its peripheral devices operates correctly.

2. Test Procedure

- 2.1. Check the Workstations are connected with all the peripheral devices as per the BOQ
- 2.2. Power On the Workstation and devices.
- 2.3. Check the operation of all devices

3. Test Results Records

All hardware associated with NMS are working properly : Ok / Not Ok

4. Test Remarks

Equipment Under Test: _____

Test Date and Time: _____

Site Name: _____

Tested By : _____ **Witnessed By** : _____
(Manufacturer/Contractor) (POWERGRID/Constituent)

Date : _____ **Date** : _____

4.2 SAT-II

TPS-14: Ethernet Channel Testing (SDH)

Equipment Under Test : SDH Equipment along with Ethernet Interface Unit

Test Parameter : Throughput, Latency, Packet Loss Measurement and Ping test of Ethernet Interface

1.0 TEST DESCRIPTION

To verify that Ethernet card is in compliance with the specifications of IEEE 802.3/RFC-2544 standards.

2.0 TEST EQUIPMENT

1. Ethernet Analyser
2. Local Craft Terminal (LCT)
3. Low loss optical patch cord & LAN cable

3.0 TEST PROCEDURE

1. Connect the SDH nodes Node-A & B with LCT.
2. At Node-A and B, Configure WAN bandwidth of the Ethernet interface as per channel plan.
3. Connect the Ethernet Analyser to LAN port of SDH equipment with UTP cable. Set the LAN port to Auto Negotiate mode.
4. At Node-B, set the Ethernet Analyser in Layer-2 loop back mode.
5. At Node-A, start the RFC 2544 test in the Ethernet analyser, set the test parameters for throughput, latency and packet loss test, set the frame length to 1518 bytes.
6. Measure the throughput, latency & packet loss.
7. All links will be tested for 1 min.

4.0 Test Result Record

A. Throughput

Anticipated result		Actual result
Bandwidth	Throughput	
2Mbps	As per applicable RFC-2544 Standard	
6 Mbps	As per applicable RFC-2544 Standard	
10 Mbps	As per applicable RFC-2544 Standard	

The throughput of the Ethernet card should not be less than the bandwidth configured.

B. Latency

Anticipated result		Actual result
Bandwidth	Latency	
2 Mbps	As per applicable RFC-2544 Standard	
6 Mbps	As per applicable RFC-2544 Standard	
10 Mbps	As per applicable RFC-2544 Standard	

The actual latency should be less than the value tolerated in the worst case.

C. Packet Loss

Anticipated result		Actual result
Bandwidth	Packet loss ratio	
2 Mbps	As per applicable RFC-2544 Standard	
6 Mbps	As per applicable RFC-2544 Standard	
10 Mbps	As per applicable RFC-2544 Standard	

The actual frame loss ratio should be less than the value tolerated in the worst case.

D. Ping Test

Connect the laptop to Ethernet port under test at both the nodes. Run the ping test

Test Result:

Both laptops ping each other thro Ethernet Channel : Ok / Not Ok

There should be No Packet Loss : Ok / Not Ok

1.1 Test Remarks

Equipment Under Test: _____

Test Date and Time: _____

Site Name: _____

Tested By : _____ **Witnessed By** : _____
(Manufacturer/Contractor) (POWERGRID/Constituent)

Date : _____ **Date** : _____

TPS-15: Measurement of BER For SDH Link

Equipment Under Test : FO EQUIPENTS (SDH)

Test Parameter : Bit Error measurements

1. Test Descriptions

To check the BER Measurements for End to End links for SDH Equipment.

2. Test Equipments Required

- LCT
- BER Tester

3. Test Procedure

- Configure an E1 channel from remote end to local end.
- Apply a software loop on remote end E1 channel through LCT.
- Test the loop back with E1 tester on local end for 1 hours/12 hours as required @10% of the link will be test for 12 hours.

Note: - 1. All BER have to be done for only 1 hour except for 10% of the link (12 hours).

4. Test Results Records

Test item	Ok / Not Ok
The test results recorded there should be no error during this period as per ITU-T recommendation G.821	

5. Test Remarks

Equipment Under Test: _____

Test Date and Time: _____

Site Name: _____

Tested By : _____
(Manufacturer/Contractor)

Witnessed By : _____
(POWERGRID/Constituent)

Date : _____

Date : _____

TPS-16: Delay measurement

Equipment Under Test : FO EQUIPENTS (SDH)

Test Parameter : Delay measurements

1. Test Descriptions

To Measure the transmission delay in the path of the network for SDH Equipment.

2. Test Equipments Required

- LCT
- BER Tester

3. Test Procedure

- Configure an E1 channel from remote end to local end.
- Apply a software loop on remote end E1 channel through LCT.
- Test the loop back with E1 tester on local end.
- Once there is no alarm in tester, open the delay measurement and simulate test.
- Total delay in the path is measured and displayed.

4. Test Results Records

Test item	Measured value	Ok / Not Ok
Delay measurement should not be more than 50 msec		

5. Test Remarks

Equipment Under Test: _____

Test Date and Time: _____

Site Name: _____

Tested By : _____ Witnessed By : _____
(Manufacturer/Contractor) (POWERGRID/Constituent)

Date : _____ Date : _____

4.3 SAT-III

TPS-17: End to End testing of Voice circuits

Equipment Under Test : FO EQUIPMENTS (SDH) & TERMINATION EQUIPMENT SUB-SYSTEM
Test Parameter : End to End testing of Voice circuits

1. Test Descriptions

To check the individual voice circuits originating from PLCC, PABX or phones are working properly.

2. Test Procedure

- Make a phone call to all configured voice circuits from the station under test.
- Check the call initiation, Quality of Voice and Call termination is happening properly.

3. Test Results Records

Call initiation is proper : Ok / Not Ok
Quality of Voice is good : Ok / Not Ok
Call Termination is proper : Ok / Not Ok

4. Test Remarks

Equipment Under Test: _____

Test Date and Time: _____

Site Name: _____

Tested By : _____
(Manufacturer/Contractor)

Witnessed By : _____
(POWERGRID/Constituent)

Date : _____

Date : _____

TPS-18: Testing of NMS Functionality

Equipment Under Test : FO EQUIPMENTS (SDH)
Test Parameter : End to End testing of Voice and Data circuits of Existing System

1. Test Descriptions

To check all Data and Voice circuits originating from RTU, PLCC, PABX or phones are working properly.

2. Test Procedure

- Make a phone call to Existing configured voice circuits from the station under test.
- Check the call initiation, Quality of Voice and Call termination ishappening properly.
- Check the Existing Data are reporting to corresponding Sub-LDC and SLDC.

3. Test Results Records

Call initiation is proper : Ok / Not Ok
Quality of Voice is good : Ok / Not Ok
Call Termination is proper : Ok / Not Ok
Data reporting is proper : Ok / Not Ok

4. Test Remarks

Equipment Under Test: _____

Test Date and Time: _____

Site Name: _____

Tested By : _____ Witnessed By : _____
(Manufacturer/Contractor) (POWERGRID/Constituent)
Date : _____ Date : _____

TPS-19: Protection Switching and Synchronization of Equipment

Equipment Under Test : NMS System

Test Parameter : Demonstration of the standard features of the NMS System

1. Test Descriptions

To verify that the entire standard features of NMS System are working properly as per technical specifications requirements.

2. Test Parameters

- Configuration Management
- Performance Management
- Fault Management
- Security Management

3. Test Procedure

CONFIGURATION MANAGEMENT

- Connect the TNMS system with the management interface of SDH equipment by using Ethernet cable.
- Ensure the SDH equipment is working.
- Login NMS as user of advanced level.
- Check the NMS whether it can establish and maintain the network topology.
- Check the NMS whether it provides the tools for planning, establishing and changing the static equipment configuration, this item can be conducted by changing some parameters & cross connection of the SDH equipment.
- Check the NMS whether it provide verification testing to support new equipment installation, this can be tested by adding a new NE.
- For creating the cross connection, establish the cross connection between any of the two ports in the same or different card.

FAULT MANAGEMENT

- Display Equipment Status, Display graphical, topological & Map type and Display the use of colour on links and Nodes.
- Connect the TNMS system with the management interface of SDH equipment by using

Ethernet cable.

- Ensure the SDH equipment is working.
- Login NMS as user of advanced level.
- Generate the various alarms; check the NMS for relevant alarm status.
- For example, pull out one card from SDH sub-rack, check the NMS for alarm of that fault.
- Insert the card, and then the alarm disappears.
- Check the alarm history, which includes all alarm events.
- Check the capability of alarm retrieval filter. Change the setting and retrieve.
- Check the colors for different level alarm events.
- Print alarm report.

SECURITY MANAGEMENT

- Connect the TNMS system with the management interface of SDH equipment by using Ethernet cable.
- Ensure the SDH equipment is working.
- Login as Administrator
- Add a user and define the user profile.
- Login as user and verify that user is able to perform various tasks as per profile.

PERFORMANCE MANAGEMENT

- Connect the TNMS system with the management interface of SDH equipment by using Ethernet cable.
- Ensure the SDH equipment is working.
- Configure a E1 interface and run performance management for specified interval.
- Monitor events & thresholds.
- Generate reports on daily, weekly, monthly and yearly basis containing system statistics.

LCT FUNCTIONALITY TEST

- Connect the LCT to the SDH equipment through LCT interface.
- Ensure the SDH equipment is working.
- Login the LCT.

- Change some configurations of the equipment.
- Get the fault information from the SDH equipment.

4. Test Results Records

Sr. No.	Test Description	Results (OK / Not OK)
1.0	CONFIGURATION MANAGEMENT	
1.1	Capability to establish and maintain the backbone topology.	
1.2	Capability to provide graphical maps depicting the sub-rack configurations.	
1.3	Capability to plan, establish and change the static equipment configuration.	
1.4	Verification testing to support new equipment installation.	
1.5	Cross-connect capability between any of the two ports in same or different card.	
2.0	FAULT MANAGEMENT	
2.1	After generating an alarm, it is automatically displayed.	
2.2	Alarm has been shown automatically when there is card failure.	
2.3	NMS can maintain an alarm summary of unacknowledged current alarm.	
2.4	NMS can maintain an alarm history.	
2.5	Operator can acknowledge and clear alarms.	
2.6	Alarm retrieval filter is available.	
2.7	Alarms can be classified and configured as critical alarms, major alarms and minor alarms, in different colors.	
2.8	Alarm reports can be extracted.	
3.0	SECURITY MANAGEMENT	
3.1	Security Management functionality allows user addition and user profile definition.	
4.0	PERFORMANCE MANAGEMENT	
4.1	Performance Management can be enabled for specific interface.	
4.2	The Measurement interval can be selected.	
4.3	Monitor events & thresholds.	

4.4	Generate reports on daily, weekly, monthly and yearly basis containing system statistics.	
5.0	LCT Functionality Test	
5.1	LCT can get fault information from the connected SDH node.	
5.2	LCT is able to change the configuration of the connected SDH node.	
5.3	LCT is able to change the configuration of connected SDH node.	

5. Test Remarks

Equipment Under Test: _____

Test Date and Time: _____

Site Name: _____

Tested By : _____
 (Manufacturer/Contractor)

Witnessed By : _____
 (POWERGRID/Constituent)

Date : _____

Date : _____

TPS-20: End to End Data Channel testing

Equipment Under Test : TERMINATION EQUIPMENT SUB-SYSTEM

Test Parameter : End to End Data Channel testing

1. Test Descriptions

To check the channel performance of interface cards as below :

- FXO/FXS voice cards
- VF E&M 4w Cards
- Async. Data card

2. Test Equipments Required

- BER Tester
- Telephone Instrument
- VF Tester

3. Test Procedure

For FXO/FXS Voice cards

- Connect the Telephone Instrument at station under test and any remote station
- Make a telephone call to remote station.
- Check the quality of Voice.

For 4 w VF E&M cards

- Connect the VF Tester to channel under test
- Give the loop back at remote station
- Send the frequency of 1 KHz, Level 4 db thro VF Tester
- Measure the return frequency and level
- Results should be same with $\pm 5\%$ variation
- Perform the test on 30% of all channels

For Async. Data channel card

- Connect the BER tester to channel under test
- Give the loop back at remote end of the channel
- Measure the BER for 5 min.
- There should be no error during this period.
- Perform the test on 30% of all channels

4. Test Results Records

For FXO/FXS cards

Card Serial No. : _____

Call can be established between two stations : Ok / Not Ok

Voice Quality is Good : Ok / Not Ok

For 4w VF E&M Cards

Card Serial No. : _____

Channel No	Tx Frequency (KHz) / Level (db)	Rx Frequency (KHz) / Level (db)	Test Status
1	1 Khz / 4 db		Ok / Not Ok
2	1 Khz / 4 db		Ok / Not OK
3	1 Khz / 4 db		Ok / Not OK
4	1 Khz / 4 db		Ok / Not OK

Card Serial No. : _____

Channel No	Tx Frequency (KHz) / Level (db)	Rx Frequency (KHz) / Level (db)	Test Status
1	1 Khz / 4 db		Ok / Not OK
2	1 Khz / 4 db		Ok / Not OK
3	1 Khz / 4 db		Ok / Not OK
4	1 Khz / 4 db		Ok / Not OK

For Async. data channel card

Card Serial No. : _____

Channel No.	BER	Test Status
1		Ok / Not Ok
2		Ok / Not Ok
3		Ok / Not Ok
4		Ok / Not Ok

Card Serial No. : _____

Channel No.	BER	Test Status
1		Ok / Not Ok
2		Ok / Not Ok
3		Ok / Not Ok
4		Ok / Not Ok

TPS-21: Interfacing with Existing Communication System

Equipment Under Test : FO EQUIPMENTS (SDH)

Test Parameter : Protection Switching and Synchronization of Equipment

Pre-requisite : All the synchronization clock & associated items installed as per approved Synchronization plan

1. Test Descriptions

- a) To check the Failure conditions and protection switching is working properly for all protections on Control cards, Optical Cards (protection switching for ring network wherever applicable).
- b) To check the Failure conditions and protection switching is working properly for protections of Optical Cards/interfaces in ring network wherever applicable.
- c) To check the Synchronization of the Equipment is as per the approved Sync. Plan.

2. Test Equipments Required

- BER Tester

3. Test Procedure

Control Card

- Control cards work on 1+1 protection. 1 protection card for 1 workingcard.
- Make the equipment work on normal status.
- Pull out the working Control card.
- The protection Control card should take over, and traffic should be restored.

Optical Card

- Optical cards work on 1+1 protection. 1 protection card for 1 workingcard.
- Make the equipment work on normal status.
- Pull out the working Optical card.
- The protection Optical card should take over, and traffic should be restored.

For both the cards make software loop on any data/E1 channel at remote end and put in the BER testing mode. Check that during both the test the traffic is restored automatically.

Synchronization

- Check the Synchronization Cabling/connection is as per approved Sync. Plan.
- Check the sync. Priority switching on protected path through LCT/NMS.

4. Test Results Records

- a) Traffic restored automatically even if one Control and Optical card terms Faulty : Ok / Not Ok
- b) No Clock failure alarm during the protection switching : Ok / Not Ok
- c) Check Synchronization cabling/connection/Configuration is as per the approved Synchronization Plan : Ok / Not Ok
- d) Check the sync. Priority switching on protected Path through LCT/NMS : Ok / Not Ok

5. Test Remarks

Equipment Under Test: _____

Test Date and Time: _____

Site Name: _____

Tested By : _____ **Witnessed By** : _____
(Manufacturer/Contractor) (POWERGRID/Constituent)

Date : _____ **Date** : _____

TPS-22: Testing of integration of supplied NMS/NE with regional UNMS/OSS (if available)

Tested By : _____ **Witnessed By** : _____
(Manufacturer/Contractor) **(POWERGRID/Constituent)**

Date : _____ **Date** : _____

TPS-23: Comprehensive Cyber Security Tests in compliance to latest cyber security guidelines issued by CEA/MoP or any other govt department.

Tested By : _____ **Witnessed By** : _____
(Manufacturer/Contractor) **(POWERGRID/Constituent)**
Date : _____ **Date** : _____

Section: Repeater Shelter

1 Introduction

This section describes the functional requirement, major technical parameters and all the testing requirements for telecom shelter system, including its sub-systems, Air-conditioning system, DG Set, PIU & 48V DC Power Supply.

1.1 Repeater Shelter Requirements

1.1.1 Shelter Dimensions

The minimum internal and external dimensions of the shelters shall be as per Table 1.1 as specified below:

Table 1.1: All dimensions are in mm

SNo.	External	Length (L)	Width (W)	Height (H)
1	External	4500	2700	3160
	Internal	4340	2540	3000

1.1.2 General

The shelters shall be protected and insulated to achieve sound proof, thermal resistance and impact withstand capabilities. The shelters shall be 100% leak and water proof with IP 55 protection. The shelters shall be maintenance free having minimum life of 15 years. These shelters shall be suitable for outdoor and may be mounted at any location including ground and rooftop and in any climatic conditions. The shelters shall be easily assembled and installed at site. The shelters shall be re-locatable as and when required.

1.1.3 Shelter Panels

The shelter shall be made of “sandwich insulated panels” 80 mm thick with Poly Urethane Foam (PUF) as filler material between polyester pre-coated cold rolled aluminium sheets. The insulation characteristics of PUF material shall conform to Clause no. 1.1.19 of these specifications.

For Steel shelters, the thickness of the inner-side and outer steel sheets except floor panel sheets shall be minimum 0.8 mm and 0.6 mm respectively. For Aluminium shelters, the thickness of both inner side and outer side aluminium sheets except floor panel sheets shall be minimum 0.91 mm. The outer bottom sheet shall be hot dip galvanised steel sheets and aluminium sheets of minimum 1.0 mm and 1.2 mm thickness respectively to avoid rusting of the bottom panel. The sandwich panels shall be manufactured by high pressure injection technique. The panels to be provided with tubular element precast in panels while foaming to form an integral part through this precast element GI steel rods of required sizes shall be inserted and fastened to top and bottom structures. The steel and aluminium sheets of standard and reputed make shall only be used.

1.1.4 Floor

The floor shall consist of standard PUF sandwich panels suitably reinforced to support the minimum load capacity of 2000 kg/m² and having at least 19 mm Marine plywood covered with anti static PVC flooring. In case of floor panel, 19 mm Marine plywood shall be provided on top of the panel and no steel or aluminium sheet shall be provided inside the panel. The anti static flooring shall be provided with pacific blue anti static vinyl robust rolls of at least 2 mm thickness. The floor shall be even surfaced,

scratch proof having long life. The installation of various proposed equipment shall be possible either by direct placement on the floor or by grouting to the floor or through C rails. The Contractor shall submit the reinforcement and other details calculations in support of the meeting the load capacity.

1.1.5 Roof

Roofs shall be made of the panels same as specified for walls. A secondary slanting roof of suitable material shall be provided to protect the primary roof from direct sunlight and rainwater. A minimum down slant of 1:50 shall be maintained from front to back. The secondary roof shall have minimum projections and shall be hidden by angular profiles on the rooftop to decrease the aerodynamic effect and improve on aesthetics. The secondary roof shall be suitably clamped/ bolted to the shelter panels to withstand the specified wind load. The details of the secondary roof and its attachment arrangement shall be submitted for Employer's approval during detail engineering. The cable tray shall be attached suitably from the roof and the roof shall have sufficient strength to support the load of cable trays and the cables installed on the cable tray.

1.1.6 Door

The Shelters shall have one door for main entrance. The door dimensions shall be 1000 mm (W) X 2200 mm (H). Main door opening outwards shall be provided with external and internal handles/knobs respectively. A reputed make lock shall be provided in door handle. The make of the lock shall be got approved during detail engineering. The door can be opened from inside when locked. Door, when locked cannot be removed even if the hinges are removed. The door shall generally be hinged at right, however, other option may be also required at some sites to meet the actual site condition. The door shall have aluminium biddings extrusions in door/jamb profile, replaceable and suitable neoprene rubber gaskets around its border for proper weather proofing. The door shall also be equipped with a hydraulic auto closure and the door latch / stopper shall be provided to keep the door in open position. The door shall have a limit switch to indicate intrusion and switch on one light provided inside the shelter. A canopy of minimum size 1200 mm X 500 mm shall also be fixed up above the external light / door for protection from direct sun/rain. The canopy shall suitable slope and shall be covered from both sides.

1.1.7 Jointing

All panel to panel connections shall be made with eccentric cam locks or suitable locking system. The wall to floor and wall to roof jointing shall be made with angular frames of suitable size. The panel to panel jointing at the corners shall either be suitably angular frames of suitable size or a single corner panel may be provided. All internal corners shall be jointed suitable angles. All the joints shall be suitable sealed with PU or silicon sealant to provide 100 % leakage and water proofing. The Contractor shall submit the drawing indicating details of all joints in support of meeting the specified requirement.

1.1.8 Opening

The shelter shall have provision for openings for required air-conditioners, piping and all electrical and optical cablings on the wall panels. The details of openings required for different applications and the locations of the openings shall be decided during detail engineering. All openings shall be custom built based upon the actual application required at each site. The Contractor shall provide the required cut outs for above purpose. Any sealed cut outs required for future use may also be provided and the size of this cut out shall be finalised during detail engineering. All the openings shall be sealed for water and leak proof with suitable flexible sealing arrangement for the proposed cable connections and also for addition and deletion of cables/pipes in future. The sealing arrangement shall be fire retardant and type/make/details shall be got approved by the Employer.

1.1.9 Insulation

The PUF to be used for insulation of the panels shall be CFC free and conforming to latest IS 12436 standards or equivalent International standard. The other parameters shall be as per Table 1.2 as given below:

Table : 1.2

SNo.	Items	Required Parameter
1	Thickness	78.6 mm
2	Density	40 kg/m ³
3	Compressive Strength	1.2 kg/cm ²
4	Tensile Strength	3.6 kg/m ²
5	Bending Strength	4.0 kg/m ²
6	Adhesion Strength	2.9 kg/m ²
7	Dimensional Stability	At (-) 25 oC : 0.1%, at 38 oC : 0.1% and at 100 oC : 0.4%
8	Temperature Range	(-)15 oC to 95 oC
9	Thermal Conductivity	0.02 kcal/hr/m/oC
10	Fire Resistance	As per BS-4735 horizontal burn < 125 mm
11	Water Absorption	0.2 % @100% RH
12	Vapour Permeability	0.08/0.12 g/hr/m ²
13	Self Extinguishing	Yes
14	Biodegradable	Yes

The Contractor shall submit the earlier carried out type tests reports for PUF material. In case the contractor does not submit the reports or the submitted reports are not meeting the requirements, the contractor shall carry out the type tests on PUF material for the following:

Thickness, Density, Compressive strength, Tensile Strength, Dimensional Stability, Thermal Conductivity and Fire resistance.

1.1.10 Heat Transmission Coefficient

The installed shelter with one door shall have the heat transmission coefficient $K \leq 0.3$.

1.1.11 Colour

The colour shall be stabilised grey on all external sides and off white on all internal sides. The colour of the slanting roof shall also be stabilised grey. However, the actual colouring scheme shall be finalised during detail engineering.

1.1.12 Fire and Smoke Detection System

Suitable fire & smoke detection system shall be provided in each of the shelters. The offered fire & smoke detection system shall work on DC supply (-48V) being provided by the Contractor under this contract. In case, the smoke detector and fire alarm system requires other voltage than the above stipulated voltage (-48V DC) for operations, suitable converter & hardware shall also be provided by the Contractor. The Contractor shall provide all required cabling & accessories for full functioning of the offered system with both power supplies. At least two ionisation type smoke detectors along with fire detection panel shall be provided below the roof panel in strategic locations inside the shelter. The alarm should activate only if both fire detectors are actuated to avoid any false alarm. The details, locations and its various logistics shall be finalised during detail engineering. The operation/activation of the fire detector shall result in the following:

- a. An external visual signal and audible alarm sounded outside the shelter.
- b. A signal to be given to the telecom equipment panel through potential free dry contact as a local alarm for its remote monitoring in the control centre.
- c. Suitable pilferage proof enclosure for visual and audio alarm outside the shelter.

All the detectors installed shall be tested for actuation and its required operations during SAT. The exact method of the testing shall be detailed in SAT procedures.

1.1.13 Lighting system

Normal and emergency lighting shall be provided inside the shelters. The normal lights shall consist of two nos. (36 Watts) of reputed make fluorescent lights along with requisite fittings and shall be powered with ac supply from ACDB. Two nos. emergency light with requisite fittings shall also be provided which shall be powered with dc supply available (-48 V DC) for telecom equipment from DCDB. In the event, the emergency lighting system requires other voltage than the above stipulated voltage for operations; suitable converter & hardware shall be provided by the Contractor. The outside light shall be bulk head type, powered with ac power supply from ACDB, provided at top of the door and covered with the door canopy. The bulk head type shall be provided with metallic guard to prevent pilferage. The switch of both internal and external lights shall be inside the shelter but adjacent to the entrance for easy accessibility. Additionally, at least one of the normal lights inside the shelter shall be lit up with the opening of the shelter door. One 5 A / 15 A duplex socket with switch shall also be provided in addition to the requisite switches for the normal and emergency lights.

1.1.14 Cable Tray

The cable tray of size minimum 300 mm width made of Fibreglass Reinforced Polymer (FRP) material shall be provided inside/outside the shelter for supporting various cables and shall be attached to the roof top/wall panels. The alternate material for the cable tray, if required shall be with specific approval of the Employer. The cable trays shall have sufficient strength to take loading of various cables like fibre optic cables, various power, signal & control cables, earthing flats etc. The rungs along the cable ladder shall be separated by not more than 300 mm. The colour of the cable tray shall match with the inside colour of the shelter. The Contractor shall submit the cable tray details for Employer's approval. The cable tray shall run along the four sides just below the ceiling with smooth curvatures at the bends/corners. The actual routing including length and height of the cable tray for each site shall be finalised during detail engineering. The Contractor shall clamp the cables suitably with the trays after installation of the cables.

1.1.15 C – Rails

C-rails made of extruded aluminium alloy of suitable size along with required number of lock-nuts shall be provided inside and outside the shelter to support various items like lighting, AC Distribution Box (ACDB), DC Distribution Box (DCDB), Fire detector along with the panel, cables and all other accessories. The C-rails may also be used for supporting cable trays from the roof, mounting of equipment on the floor and on the wall. The requirement of C-rails shall be finalised during detail engineering.

1.1.16 Energy Meter Box

An IP 55 compliant weatherproof box shall be provided for housing the energy meter along with MCBs and fuse units. The energy meter box shall have two different doors and compartments, one for accessing/housing energy meter and another for accessing/housing MCBs and fuses. The energy meter box shall have glass for view of meter reading from outside. The energy meter box shall be of Fibreglass Reinforced Polymer (FRP) material. The alternate material, if required, shall be with specific approval of the Employer. The box shall be provided with pad lock arrangement and shall be installed on external shelter panels with suitable fittings. Proper sealing shall also be done

to avoid any water leakage into the panel. The size and locations of meter installation shall be finalised during detail engineering.

1.1.17 Loading Capacity

Minimum roof loading capacity: 250 kg/m²

Minimum floor load capacity: 2000 kg/m²

Minimum wall load capacity: 300 kg/m²

The above load capacities have been identified as minimum requirement. However, during detail engineering, to meet the actual load requirement for cable tray, ACDB, DCDB, C-rails, Air-conditioning system, battery, batteries chargers, telecom equipment, lighting etc. to be supplied and installed inside the shelter, the actual localised loading requirement may be higher and the supplied shelter loading capacity shall meet the actual localised loading requirement at no additional cost to POWERGRID.

1.1.18 Structural Stability

- Resistant to various volumes of rain, dust & sand impinging from various directions over different durations and different speeds.
- Resistant to corrosion against water, industrial air and saline air.
- Resistant to decomposing vegetation, rodents, termites and micro-organisms.

1.1.19 Survival wind speed

The shelter shall be designed to withstand a wind load of 200 kmph.

1.1.20 Cables and Cabling

All cables and cabling of required size and capacity shall be supplied, installed and terminated with necessary and required accessories among all the equipment/systems being supplied under this Package. The cables from cable ladder to equipment cable entry height shall be installed in the wall of the shelter in PVC cable conduits and in flexible conduits from shelter wall to equipment. The cables shall be dressed properly and suitably attached with the shelter panel. No hanging cables shall be allowed.

1.1.21 Structural

All structural steel shall conform to latest IS: 2062 or equivalent International standard. The ISMBs shall conform to IS – 808 or equivalent International standard. The structural MS pipes shall conform to IS:1161 or equivalent International standard. The steel work shall be galvanised after full fabrication as per latest IS standards and the coating thickness shall be greater than 127 micron. All welding shall be as per IS – 816 or equivalent International standard. All nuts and bolts shall be galvanised and conform to IS : 6639 or equivalent International standard. All fittings and hardware used in the shelters shall be made of corrosion-resistant aluminium or galvanised steel as specified in the relevant clauses of this specification.

The requirement of steel/aluminium sections shall also be provided and no separate payment shall be made in this regard.

1.1.22 Earthing

For satisfactory operation of the equipment inside the shelter, good and proper earthing is required at each site. The earthing resistance generally varies depending on soil resistivity. The earthing system at each site shall be provided by the Contractor with earthing resistance not exceeding the five (5) ohms. The Contractor shall provide the pipe type earthing along with the necessary hardware and accessories required. Minimum two earth pits shall be made at each location. However, if required resistivity is not met, then,

sufficient nos. of pipe type earthing shall be provided by the Contractor. The Contractor shall submit the earthing pit diagram for Employer's approval.

An earthing ring of copper strip of minimum size 25mmX3mm shall be made inside the shelter. Each equipment shall be connected to above earthing ring through 70sqmm copper cable. The connectivity from earthing pit to the shelter earthing ring shall be made by the Contractor through two (2) nos. of 50 X 6 mm GI strips. The connection of GI strips with the copper strips shall be made through flexible copper cable and bi-metal washers for proper connectivity. The GI strips for earthing pit to shelter shall be buried inside the ground.

Three days after completion of the earthing pit, the earth resistance shall be measured in the presence of Employer's representative and test results for each location shall be submitted for Employer's approval.

All the equipment shall be connected properly to this earthing system for their safe operation.

1.1.23 Foundation System for Shelter

The Contractor shall design and construct complete foundation system for all finalised shelter locations depending on the type of soil, including supply and furnishing all the material & labour, tools & tackles, plant and machineries etc. as required for successful completion of the job. The foundation system shall also include the following:

- Site preparation
- Soil characteristics assessment as required for foundation design for each site including detail soil investigation, if required.
- Water level assessment
- Raising of site level above maximum flood limit level to avoid any water logging in the shelter area.
- Concrete pedestals (in situ) along with base slab for the foundations located on concrete pedestals for roof top locations along with supply and fixing of necessary holding down / anchor bolts.
- PCC and finish of surface below and around shelter location with suitable slope. Installation of base frame and sub-frames on the pedestals through
- ISMB channels. Stair access for shelter.

1.1.24 Site Preparation at Shelter locations

For each of the shelter to be installed on the ground, the Contractor shall execute the work for site preparation, such as clearing of the site, levelling of the site, the supply and compaction of fill material (if required), excavation and compaction of backfill for foundation, trenches etc with available excavated earth. At certain locations, the finished ground level (FGL) site shall be fixed above High flood level (HFL) to avoid water logging in the shelter area. The site shall be prepared to meet the specified requirement for each site and up to satisfaction of the Employer. If fill material is required for site preparation, the fill material shall be provided with suitable protection so as to prevent the erosion by wind and water from its final compacted position or the in-situ position of undisturbed soil.

Quantities of Earth filling with suitable protection have been identified in BoQ for above purpose.

Backfill material around foundation and shelter shall be suitable for the purpose for which it is used and compacted to the satisfaction of the Employer. Excavated material not suitable for use or not required for backfill shall be disposed off in area as directed by the Employer, including all leads and lifts.

Whenever water table is met during the excavation, it shall be dewatered and water table shall be maintained below the bottom of the excavation level during excavation, concreting and backfilling.

For roof top shelters, the Contractor shall also prepare the site suitably for shelter installation on the pedestals. In all cases, each site shall be fully prepared before start of foundation activities up to satisfaction of the Employer.

1.1.25 Concrete Pedestals and Foundation system

Two types of foundations are envisaged for shelters viz. (i) required for shelters to be installed on ground & (ii) required for shelters to be installed on roof top of a building. The foundation of shelters to be installed on the ground shall consist of RCC pedestals of minimum 600 mm above levelled ground. The depth of pedestals below the ground shall be minimum 1500 mm including bottom slab. The size of bottom RCC slab of the foundation shall be minimum 600 mm x 600 mm for a minimum 250 mm depth. The reinforcement shall be as stipulated at clause 2.4.4 below. The PCC (1:4:8) of minimum depth 75 mm shall be provided below the bottom slab of minimum size 750 mm X 750 mm. The size of the pedestals shall be minimum 300 mm X 300 mm. The grade of concrete shall be M20 (1:1.5:3). The concrete cover for the reinforcement shall be minimum 50 mm.

The foundation of shelters to be installed on the roof top shall consists of RCC pedestals of size minimum 300 mm X 300 mm and 300 mm above roof surface of M20 (1:1.5:3) grade. The bottom of the pedestal shall be connected and attached with the existing roof structure/slab. The reinforcement shall be as stipulated at clause 2.4.4 below.

The exposed portion of the concrete pedestals shall be plastered with 1:4 cement plaster for smooth finish.

The above pedestal dimensions are minimum requirement and the Contractor shall provide the required size of pedestals depending upon the soil bearing capacity and other soil parameters of each site to support the installed shelter along with all equipment. The detailed design for all above type of foundations shall be submitted to the Employer and got it approved before commencement of work at site.

The shelter shall be fixed to the pedestals through ISMBs 200 mm minimum and sufficient number of sub-frames with suitable anchor bolts. The required ISMBs and sub-frames shall be provided by the Contractor as part of shelter/foundations. The required number of pedestals shall be provided for shelter installations, however, minimum one pedestal is to be provided at each corner of the shelter. The Contractor shall provide the required and necessary foundation system at each site irrespective of soil to meet the requirement and submit the civil/structural/foundation design and drawings along with the load calculation for Employer's approval. All required foundation system and related works shall be in Contractor's scope and no additional payment shall be paid to the Contractor irrespective of soil characteristics and site conditions.

The suitable staircase shall be provided at each shelter location in front of the door for easy entry into the shelter as a part of foundation/pedestal system and no separate payment shall be made in this regard.

1.1.26 Concreting

After completion of foundation work at each shelter location, PCC (1:2:4) of depth minimum 100 mm shall be provided throughout the floor inside shelter boundary (approximate dimension of shelter location has been considered as 10x10 sq. m). There shall be adequate slope in the Shelter area PCC to avoid water logging.

The Contractor shall also provide the RCC platform of about 600 mm height for installation of DG set. The exact area and the height of RCC required for DG set and shelter area shall be finalised during detailed engineering.

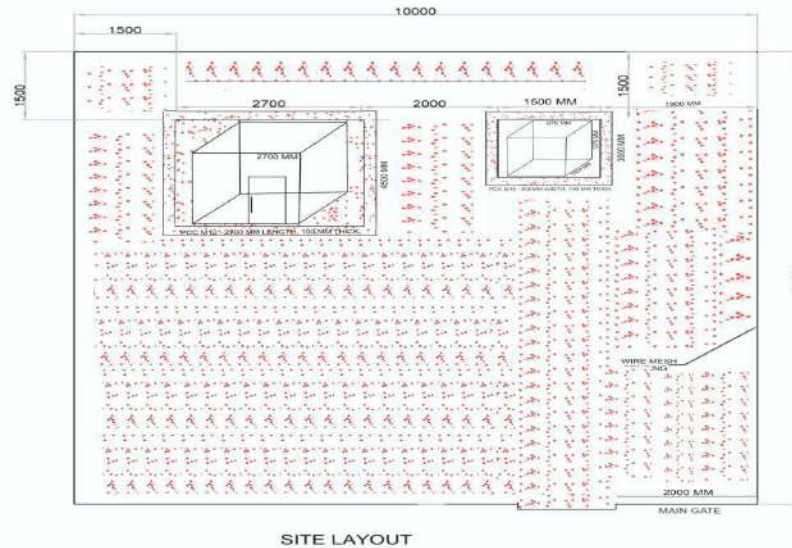

1.1.27 Properties of Concrete

The cement concrete used for foundation shall be of grade M-20 corresponding to 1:1.5:3 nominal mix ratio with 20 mm coarse aggregate. All the properties of concrete regarding its strength under compression, tension, shear, punching and bend etc. as well as workmanship will conform to latest IS standards or equivalent International standard.

The Portland cement used in concrete shall conform to 33 grade (IS:269) or 43 grade (IS:8112) or 53 grade (IS:12269) or equivalent International standards.

The Pozzolena cement used in concrete shall conform to IS : 1489 or equivalent International standard. The curing time of Pozzolena cement shall be decided at the time of execution of the work under the contract based on the certificate from a reputed laboratory which will be obtained and submitted by the Contractor. Cement of only POWERGRID approved make shall be supplied.

Concrete aggregate shall conform to IS: 383 or equivalent International standard.

The water used for mixing concrete shall be fresh, clean and free from oil, acids and alkalis, organic materials or other deleterious substances. Portable water is generally preferred.

Reinforcement shall conform to IS: 432 or equivalent International standard for MS bars up to 6 mm and hard drawn steel wires and to IS : 1139 and IS : 1786 or equivalent International standard for deformed and cold twisted bars 8 mm and above respectively. All reinforcement shall be clean and free from loose mill scales, dust, loose rust and coats of paint, oil or other coatings, which may destroy or reduce bond. Contractor shall supply, fabricate and place reinforcement to shapes and dimensions as indicated or as required to carry out the intent of drawings and specifications. Reinforcement of only POWERGRID approved makes shall be supplied.

1.1.28 Mixing, Placing and Compacting of Concrete

Mixing shall be continuous until there is uniform distribution of material and the mix is uniform in colour and consistency. Normal mixing shall be done close to the foundation, but exceptionally the concrete may be mixed at the nearest convenient place. The concrete shall be transported from the place of mixing to the place of final deposit as rapidly as practicable by methods which shall prevent the segregation or loss of any ingredient. The concrete shall be placed and compacted before setting commences.

Form boxes shall be used for casting all types of foundations and pedestals.

The concrete shall be laid down in 150 mm layers and consolidated well, so that the cement cream works, up to the top and no honey-combing occurs in the concrete. Preferably, a mechanical vibrator shall be employed for compacting of concrete. However, in case of difficult terrain, manual compaction may be permitted at the discretion of the Employer. Monolithic casting of foundations must be carried out. After concreting the pedestal portion to the required height, the top surface should be finished smooth.

Wet locations shall be kept completely dewatered, both during and 24 hours after placing the concrete, without disturbance of the concrete.

If the concrete surface is found to be defective after the form work has been removed, the damage shall be repaired with rich cement sand mortar to the satisfaction of the Employer before the foundation is back filled.

1.1.29 Curing

The concrete shall be cured by maintaining the concrete wet for a period of at least 10 days after placing. Once the concrete has set for 24 hours, the pit may be backfilled with selected moistened soil and well consolidated in layers not exceeding 200 mm thickness and thereafter both the backfill earth and exposed pedestal shall be kept wet for the remainder of the prescribed 10 days. The exposed concrete chimney shall also be kept wet by wrapping empty cement bags around it and wetting the bags continuously during the critical 10 days period.

1.1.30 Other associated civil works

The Contractor shall also carry out other minor civil works in the shelter area for the equipment/system being supplied under the Contract at no additional cost to the Employer.

1.1.31 Installation

The shelter shall be installed on the foundation system as specified above and to meet the actual requirement as per actual site/soil conditions. The installation of shelters shall be carried out in such a way that it shall meet all specified requirement. The installed shelters shall be suitable for both transporting in assembled condition to another location and dismantling, transporting to another site and reassembling there.

The Contractor shall make their own arrangement for AC supply / DG set during installation/testing of the system.

1.1.32 Finish

The final finish of the installed shelter system shall show good workmanship. The panels and floor shall be totally scratchproof. The floor shall not have any uneven surface. The total shelter shall be air tight, the roof and all joints shall be leak and water proof and the door shall be easily lockable & unlockable.

1.1.33 Wire Mesh Fencing System for Outside Protection

To protect the shelters along with the installed equipment, air-conditioners, DG sets etc. from vandalism, wire mesh fencing shall be constructed at each of the shelter locations installed at ground. The wire mesh size shall be of 75 mm, the nominal dia of the mesh wires shall be 3.5mm and fencing shall be at least 2.0 m height from ground level. The pipes/angles of adequate size and capacity shall be provided to support the fencing. An iron gate of minimum size of 2 m or as per site requirement with pad locking facility shall also be provided at each location to enter the protected area. The fencing system shall also be painted (one coat of primer and 2 coats of final paint) for better reliability. The paint colour shall be finalised during detailed engineering. The provisional quantities of wire mesh fencing system including the gate in running meters have been indicated in the BOQ and the actual quantity shall be finalised during detail engineering based upon the actual site conditions. All associated civil works for the fencing shall also be carried out by the Contractor. The Contractor shall submit the layout of the shelter and other equipment and the barbed wire fencing for each of the locations for Employer's approval.

1.1.34 External Alarms

The telecom equipment being provided under separate package shall have provision of taking input of external alarms from various equipment e.g. DG set, air-conditioning system, DCPS, fire & smoke detection system, PIU unit etc. The Contractor shall provide necessary dry contacts at all the equipment being provided under this package and shall wire up these up to the telecom equipment. Contractor shall integrate and extend the Potential Free Contacts minimum for the alarms indicated at Cl.6.3.5 of specification.

1.1.35 Testing of Shelter system along with all sub-systems

1.1.35.1 Type testing

The Contractor shall provide the earlier carried type test reports for the PUF material and other sub systems of the shelter.

1.1.35.2 Factory Acceptance Testing (FAT)

The following tests shall be carried out during Factory Acceptance testing (FAT):

- a. Dimensional and checks as per approved DRS/drawings
- b. BOQ verification as per approved drawings/documents
- c. Test certificates from the Original Equipment Manufacturer.
- d. Density test, Compression test and Thermal Conductivity test on the PUF material.

FAT on other items shall be carried out as specified in this specifications and relevant standards.

1.1.35.3 Site Acceptance Testing (SAT)

The site acceptance testing shall be carried out for each site. The installed system shall be powered up and all the equipment shall be tested and commissioned. The various installed system shall be tested for the specified functional requirements and shall be as per approved drawings. The SAT shall be carried in an integrated way and not individual equipment basis to demonstrate the integrated functioning of the installed system. The tests shall be carried out on following minimum items during SAT:

- i.Site preparedness, PCC and RCC.
- ii.Civil Pedestals and Steel structure for Base of Shelter System
- iii.Shelter (including water proof test)
- iv.Air-Conditioning System
- v.Cable Tray
- vi.Lighting System
- vii.Fire and Smoke Detector System
- viii.C-Rails
- ix.Earthing System
- x.Wire Mess Fencing

The detailed SAT procedure shall be submitted for Employer's approval.

1.1.36 Marking

The following information shall be provided outside the shelter and near the door engraved on a steel metal plate:

- a. POWERGRID logo and name.
- b. Project Name
- c. Shelter location name
- d. Identification no.
- e. Year of Manufacture
- f. Shelter dimension

1.2Requirements of Air Conditioning System

1.2.1 General

The air conditioning system shall be provided in the shelters to be used for housing Telecom equipment, power interface unit, VRLA batteries, battery charger etc. throughout the country. Repeater Shelters are placed for amplification of telecom signals in between the fibre optic links. The Contractor may note that these shelters are generally located in unmanned areas; therefore, the air-conditioning system shall be rugged, reliable, maintenance free and designed for long life.

1.2.2 Technical Experience

The Air Conditioners shall be offered from a manufacturer and Air Conditioners manufactured by such manufacturer should have been in operation for at least one (1) year as on the originally scheduled date of bid opening.

Bidder shall furnish the details/document in support of above Technical experience of manufacturer along with bid.

1.2.3 Operational Requirements

The air-conditioning is required for critical applications i.e. for maintaining the temperature of the critical telecom equipment inside the shelters on 24hours, 365 days of the year operation basis. Thus, to provide redundancy for such critical applications, Contractor shall offer twin circuit air conditioning system comprising of two air conditioning units packed in a single frame working in conjunction, controlled by the single inbuilt Micro processor based controller for desired operation.

Depending upon the size and location of shelter, following type of air conditioning systems shall be supplied:

- i) 2X2TR capacity air conditioning system with free cooling unit
- ii) 2X2TR capacity air conditioning system without free cooling unit
- iii) 2X1.5TR capacity air conditioning system with free cooling unit
- (iv) 2X1.5TR capacity air conditioning system without free cooling unit

Both units shall be independent of each other. The units shall run one by one in pre settable time bound cyclic ON/OFF mode. However, during running of AC unit 1, if the inside temperature of the shelter reaches to a predefined value, the AC unit 2 shall also start running to maintain the inside temperature to specified 24 oC. After achieving this temperature, the other unit shall again shut off.

Problem/ fault in one of the unit shall not hamper the working of other unit and during such fault in any of the unit; the alternate unit shall take over and continue to operate till the faulty unit is operational again.

Both units shall never start at the same time. If the condition is such that both units shall start together then internal time delay of at least 10sec shall be provided in starting of each unit to avoid surge.

In free cooling mode, the refrigerant cycle of AC unit shall be switched off and outside air (after filtration) shall be circulated inside the conditioned space through the operation of dampers provided with suitable sensors. It should be possible to run the Free Cooling Unit (FCU) on both AC & -48V DC Power supplies. This mode shall come into operation in the following conditions;

- i. When the ambient temperature is below a preset value, which is to be decided during detailed engineering.
- ii. In case of failure of refrigeration system of both the units.

The failure of free-cooling feature shall not hamper the normal operation of Air Conditioning units.

1.2.4 Operational Life

The air conditioning system to be supplied shall have operational life of 10 years.

1.2.5 Design

The air-cooled self contained package AC system shall be designed as per following conditions:

□ Rated Capacity : 1.5TR/2TR

- Type of Discharge : Free Flow.
- Air inlet Temp (Return Air) : 24 0C (DB) RH : 50
- Temperature Variation allowed : 1 0C
- Ambient Air Design Temp : 45 0C
(entering the Condenser)
- No. of Refrigeration Circuits : Two
- Type of load Factor : High sensible heat load (SHR>0.9)

1.2.6 Micro processor based Controller

The air conditioning system shall have a common microprocessor based controller for both AC units, packed within the same cabinet. The microprocessor based controller shall have the following features;

Controller	Common for AC1+AC2
Mode of Operation	RUN/TEST/ Standby mode
Temperature Setting	16 -30 deg. C with 1 deg C resolution

Temperature variation from set temperature: 1 0C

Cycle Time, Duty Changeover 2, 4, 6, 8, 10, 12 hours.

Unit Changeover	Both the AC units shall operate in pre-settable cyclic mode. Also, if one unit is faulty the controller shall be able to detect & put the other unit in operation automatically.
-----------------	--

Running of both units:

Start of IInd unit along with Ist unit in case sensor senses high temperature.

Memory Non-volatile memory for various settings supported by Battery backup eg. Set temp., working hours & ON/OFF Status

Alarms Displays

Potential Free contacts for Remote monitoring at NOC

- a) AC unit1 fails alarm
- b)AC unit2 fails alarm
- c)High Temp inside shelter alarm
- d)Power Fail alarm
- e)Indication for free cooling

In addition to the above, following minimum LED Indications shall also be available in the Controller Mimic Panel for local indication;

- a)Alarm.
- b)Power Healthy.
- c)Blower Working.
- d)Compressor Working.

Time Delay On / Off sequence delay shall be available.
Cumulative hours run For each compressor of Air-conditioning system
Free Cooling Operates the blower fans & changeover damper position to circulate outside air.
Enthalpy/Temperature : As required along with free cooling.

Further, the free cooling function may be enabled/ disabled with help of the controller.

1.2.7 Earthing

The AC equipment shall be properly earthed by connecting it to the earthing system.

1.2.8 Power Supply

The offered air-conditionings equipment shall work satisfactorily for the power supply range as mentioned at mentioned below:

Nominal Voltage: 230 V (Single phase)

Variations: $\pm 10\%$

System frequency: 50 Hz ($\pm 5\%$)

Supply and installation of all required cabling, wiring and termination and accessories including surge arrestors, motor starters, circuit breakers and switches from the power supply point/ Meter point to the various units via ACDB shall be carried out by the Contractor.

1.2.9 Testing

1.2.9.1 Type Testing

The type testing of the air-conditioning system shall conform to latest IS: 8148 standards or equivalent International standard.

1.2.9.2 Factory Acceptance Testing

The factory acceptance testing shall be carried out as per latest IS: 8148 standards or equivalent International standard.

1.2.9.3 Site Acceptance Testing (SAT)

The site acceptance testing for air-conditioning system shall be carried out by the Contractor after successful installation of the air conditioning system. The SAT shall demonstrate all its functions properly. The detailed SAT procedure shall be submitted by the Contractor for Employer's approval.

1.3 Requirements for DG Set

1.3.1 General

The DG sets shall generally be installed on ground and the required RCC/PCC floor shall be provided by the Contractor. Single Phase DG sets of rated capacity without AMF panel are required. AMF panel shall be the part of Power Interface Unit (PIU). Most of these DG sets shall be installed at unmanned sites located in rural/remote villages/towns. The DG set shall have an operational life of 10 years.

1.3.2 Technical Experience

The DG set shall be offered from a manufacturer of Diesel Generator set and Diesel Generator set manufactured by such manufacturer should have been in operation for at least one (1) year as on the originally scheduled date of bid opening.

Bidder shall furnish the details/document in support of above Technical Experience of manufacturer along with bid.

1.3.3 Generator Set Configuration

The generator set shall consist of a diesel engine directly coupled to an electric generator, together with the switchgear, controls, battery and other associated accessories required to provide continuous electric power for any duration of failure of the normal AC source. The DG sets shall be rated for continuous operation.

1.3.4 Diesel Engine

The Contractor shall provide diesel engines of standard designs of original manufacturers in their DG sets. It shall be from reputed manufacturers i.e. Kirloskar Oil Engine / Cummins / Ashok Leyland / Mahindra / Crompton Greaves / Eicher makes conforming to latest BS 5514/ ISO 3046 standards. The bidder shall submit the details of the engine along with their bid.

The diesel engine shall be direct injection, 4 stroke cycles, multi cylinder, air-cooled/ water-cooled, naturally aspirated/ turbo charged, instantly started, operating at a nominal speed of 1500 R.P.M. and capable of developing requisite Brake Horse Power i.e. the rated horsepower of the engine, at the generator synchronous speed, with all accessories attached, shall not be less than the required power as specified in the appendices. In addition, the horsepower rating shall take into account the generator efficiency, losses and maximum rated environmental conditions stipulated in Clause 1.3.19. All moving parts of the engine shall be mechanically guarded in such a manner that a human finger cannot touch a moving part. The diesel engine shall be equipped with a dry type air filter system.

1.3.5 Governor

The engine shall be equipped with class A-1 governor or better as per IS 10000 Part-VII or any other equivalent International standard. The speed regulation shall be as per the above governing class.

1.3.6 Engine Cooling

The bidder may offer air-cooled or water-cooled type DG sets. However, no preference / compensation shall be applicable for any particular type of offered DG sets. The cooling system shall provide adequate cooling to the generator set when operated on full load for prolonged periods of time at the maximum environmental conditions stated in Clause 3.3.19. In case of water-cooled engine, necessary breathing arrangement shall be provided with the radiator to take care of the expansion/ contraction of the coolant water in the radiator.

1.3.7 Fuel System

The engine shall operate on a commercial grade diesel fuel; no premium fuel shall be required. The DG set shall be provided with inbuilt fuel storage tank with capacity to last 12 hrs on 100% load. It shall be equipped with low level fuel alarm potential free contacts for connection to the Equipment NMS system.

The Contractor shall also indicate the fuel consumption of the offered DG sets at 25%, 50%, 75% and 100% of rated loads along with their bid in the DRS format.

Fuel required to carry out all kind of tests including site acceptance tests shall be supplied by the Contractor.

1.3.8 Exhaust System

The DG set shall be provided with a suitable exhaust system capable of carrying exhaust gases from the engine and dissipate them to the atmosphere as quickly and silently as possible meeting the latest noise and emission norms of CPCB. The exhaust system shall be equipped with proper heat shielding to protect personnel and facilities.

1.3.9 Starting System

The engine shall be equipped with an electric starting system with a 12/24 volt heavy duty lead acid battery of suitable AH capacity sufficient to provide a minimum of twelve (12) successive abortive starts of the engine without recharging. A suitable battery charger complete with voltage regulator, float or booster selector switch, on-off switch, digital voltmeter and ammeter shall be supplied (along with the battery) for charging the battery from mains. The battery charging system shall operate on an input of 240 V AC, 50 Hz from the ACDB. The battery shall be housed within the DG enclosure suitably.

The engine control shall provide for multiple crank start-up cycles. Each cycle shall be approximately 10-seconds of cranking followed by 10-seconds of rest. The starting circuit shall automatically be disconnected after the start up of the engine. If the engine does not start after three (user adjustable number) attempts, the starting circuit shall be disabled and an alarm indication ("over crank") shall be provided. A potential free contact shall be provided to interface these alarms with the Equipment NMS.

The starting time of the DG set in 'AUTO' mode shall be continuously and linearly adjustable from 5 minutes to 8 hours from the time of power failure sensing. The starting of DG set shall be based on the condition of the 48V DC battery voltage (being used for telecommunication equipment) and temperature inside shelter. For this purpose, the required auxiliary contacts from DC power supply system shall be available in DCPS cabinet and for sensing temperature inside shelter, the required thermostat shall be provided by the DG Contractor. The exact time setting and other settings of DG start up shall be finalised during site acceptance on site-to-site basis based on the actual site conditions.

1.3.10 Instrumentation and Controls

The Employer shall procure DG sets with the capability to extend the controls to external PIU unit equipped with AMF control panel.

The microprocessor based AMF (Automatic Mains Failure) panel shall be equipped with standard instrumentation including interlock and protection arrangement, suitable annunciation and indications etc. for proper start up, monitoring, control and safe operation of the DG set. The AMF shall start the DG set in case of AC mains failure and transfer the load from normal source to diesel generator without any human intervention. Similarly on restoration of mains supply it shall be able to transfer the load to mains supply and switch off the DG automatically.

The AMF panel shall be equipped with following minimum instrumentation:

- a). Microprocessor based relay with composite meter for digital display of;
 - i. AC mains Voltage & Generator Voltage
 - ii. Generator Current
 - iii. Power Factor
 - iv. Output KW meter

- v. Output AC frequency meter
- vi. RPM indication
- vii. Over speed indication
- viii. Engine hours indication
(Cumulative)

b). Mode selector switch for setting the panel on any one position such as OFF or Auto/ Manual/ Test. The operation of the DG set shall be possible in any of the modes.

c). Engine ON/OFF switch (Push button type)

d). Emergency Stop switch (Push button type)

e). ON delay timer for load change over.

f). ON delay timer for engine shut off.

g). Indicating lamps to indicate 'Mains ON', 'Load on Mains', 'DG Running', 'Load on DG', 'Battery charger ON'

h). Audio visual alarm for

i. Low lubricating oil pressure

ii. High water temperature (for water cooled DG)

iii.

High cylinder head temperature (for air cooled DG)

Start

failure iv.

v. DG over load.

i) Suitable battery charger complete with voltage regulator, float or booster selector switch, on-off switch, digital voltmeter and ammeter for charging the battery from mains operating 240V/ 50 Hz

j). MCCB of suitable rating

k) Two no. contactors of suitable ratings (one for DG set and one for AC mains) with overload relay.

l) Under voltage relay for Mains.

m) Instrument and control fuses.

n) Any other switch, instrument, relay or contactor etc. essential for smooth and trouble

free functioning of DG set with AMF panel. (To be specified by the bidder with complete detail of the item).

Standard colour codes and numbered ferrules shall be used for wiring the AMF panel. Sensing and control relays shall be of continuous duty, industrial control grade type. The transfer breaker shall be rated for continuous duty. The breaker shall be interlocked to ensure non-paralleling SEB power supply and DG supply.

Following automatic shut down protection system for DG set shall also be integrated in the control panel;

i. Low lubricating oil pressure shut down.

ii. High coolant (water) temperature shut down.

iii. Engine over speed shut down.

iv. Over load shut down.

v. Short Circuit shut down.

vi. Over Voltage shut down

vii. Low Fuel Level

viii. Earth Fault shut down.

ix. Emergency Stop

The AC mains supply shall be of either single Phase or three Phase. The loads connected shall be single phase in nature.

1.3.11 Alternator

The Contractor shall supply alternators in their offered DG sets only from the reputed manufacturers i.e. Crompton-Greaves / Kirloskar / FG Wilson / ELGI / KEL makes as per latest BS 5000/ IS 4722 standards. Details of alternator shall be submitted by the Contractor along with the bid.

The alternator shall be self excited, self regulated, screen protected, double bearing, brushless type, drip proof, continuous duty type, synchronous and suitable for 1500 RPM. 0.8 P.F lagging, horizontal foot mounted, with class H insulation.

1.3.14.4 Points for Neutral/Body earthing shall be available at two side of the enclosure with the help of flexible copper wires from alternator neutral, and electrical panel body respectively. The earthing point shall be isolated through insulator mounted on enclosure. The alternator shall also have a solid state type Automatic Voltage Regulator (AVR) suitable for single running with control limits of 1% from no load to full load under normal load changes. It shall be of static type and complete with cross current compensation. The regulator shall be provided with voltage adjusting potentiometer and shall be complete with all alarm contacts, internal wiring etc.

The alternator shall be capable of carrying 50% overload for a duration of one minute.

The alternator shall be suitable for 20% over speed for two minutes.

The alternator shall be capable of carrying 10% overloading for one hour in any period of 12 hrs running without injury.

1.3.12 Mounting Arrangement

Engine and alternator shall be mounted on a common MS fabricated base frame with anti vibration pads.

1.3.13DG set Enclosures

1.3.13.1 A suitable weather-proof enclosure which shall be provided for protection from rain, sun, dust etc. Further, in addition to the weather proofing, acoustic enclosures shall also be provided such that the noise level of acoustic enclosure DG set shall meet the requirement of MOEF The diesel generator sets should also conform to Environment (Protection) Rules, 1986 as amended. The enclosure shall allow sufficient ventilation to the enclosed D.G. Set so that the body temperature is limit to 50°C. The air flow of the exhaust fan shall be from inside to the outside the enclosure. The exhaust fan shall be powered from the DG set supply output so that it starts with the starting of the DG set and stops with the stopping of the DG set. The enclosure shall have suitable viewing glass to view the local parameters on the engine.

1.3.13.2 Fresh air intake for the Engine shall be available abundantly; without making the Engine to gasp for air intake. A chicken mess shall be provided for air inlet at suitable location in enclosure which shall be finalized during detailed engineering.

1.3.13.3 The Enclosure shall be designed and the layout of the equipment inside it shall be such that there is easy access to all the serviceable parts.

1.3.13.4 Engine and Alternator used inside the Enclosure shall carry their manufacturer's Warranty for their respective Models and this shall not degrade their performance.

1.3.13.5 Exhaust from the Engine shall be let off through Silencer arrangement to keep the noise level within desired limits. Interconnection between silencer and engine should be through stainless steel flexible hose/ pipe.

1.3.13.6 All the Controls for Operation of the D.G. Set shall be easily assessable. There should be provision for emergency shutdown from outside the enclosure.

1.3.13.7 Arrangement shall be made for housing the Battery set in a tray inside the Enclosure.

1.3.14 Construction Features:

1.3.14.1 The enclosure shall be fabricated from at least 14 Gauge CRCA sheet steel and of Modular construction for easy assembling and dismantling. The sheet metal components shall be pre-treated by Seven Tank Process and Powder coated (PURO Polyester based) both-in side and out side – for long life. The hard-ware and accessories shall be high tensile grade. Enclosure shall be given a lasting anti-rust treatment and finished with pleasant environment friendly paint. All the hardware and fixtures shall be rust proof and able to withstand the weather conditions.

1.3.14.2 Doors shall be large sized for easy access and provided with long lasting gasket to make the enclosure sound proof. All the door handles shall be lockable type.

1.3.14.3 The suitable material of required density and thickness shall be used with fire retardant thermo – setting resin to make the Enclosure sound proof as per CPCB standards.

1.3.15 Main Circuit Breaker of DG

The DG set shall be connected to the Input ACDB buses through main circuit breaker (MCCB type). Separate cables from DG set to the breaker shall be laid to extend DG power supply.

1.3.16 DG Set Mode of Operation

Operation of DG set shall only be allowed when the selector switch is in the Manual/Automatic/Test positions. Moving the selector switch to the OFF position shall properly shut down the generator set, remove it from the AC loads and inhibit it from starting in any mode. The DG set shall be capable of operation in the following modes;

1.3.16.1 Start Operation

- a. Auto Mode
- b. Manual
Mode
- c. Test Mode

1.3.16.1.1 Auto Mode

In the ‘AUTO’ mode, the DG Set shall start only after a set time delay when either the primary AC source has failed or conditions prevail as indicated below;

When the main source power fails, the DG set shall include detection and control to automatically disconnect the primary AC source, start the DG set and extend power to ACDB after the set time period of the timer. The time delay is continuously & linearly adjustable at site from 5 minutes to 8 hours as specified at **Clause 1.3.9**. The engine shall also start automatically after detecting a predefined temperature (20 oC to 55 oC continuous) inside the shelter or initiation from 48V DC under-voltage contact from DCPS. All required control like thermostat, extension of potential DC under-voltage contact from DCPS shall be provided by the Contractor to support the above controls.

All phases of primary AC sources voltage shall be monitored. The automatic start-up system shall detect failure or abnormal conditions specified and start the generator set. At the time of loss of primary voltage or an abnormal condition of low phase voltage, a start control shall be initiated. The automatic start shall try the start-up of the generator set for three successive attempts. If the primary AC returns during the start-up attempt, the start-up sequence shall be stopped.

If at any time during operation of the generator set the selector switch is set to ‘OFF’ position, the generator shall shut down and be disabled from starting.

1.3.16.1.2 Test Operation

A test operation of DG set shall be possible by putting the control switch in “TEST” position from where the generator shall initiate an automatic start, just as if there had been a power interruption to the primary power. Upon removal of the selector switch from “TEST” position, the generator shall initiate an automatic shutdown sequence. However, there shall be interlock such that Main circuit breaker of DG set is in ‘OFF’ condition while the engine is started in “TEST” position.

1.3.16.1.3 Manual Operation

When the control switch is in “MANUAL” position, the generator set can be started using the manual start push-button on the control panel. The generator set will be stopped by setting the control switch back to the “OFF” position or by pressing stop button on the AMF panel. During manual operation, all main and AC source breakers must be operated manually to transfer load to or from the generator set.

1.3.16.2 Automatic Shutdown

When the primary power is restored and remains normal continuously for a period of 5 minutes (locally user adjustable from 0 to 15 minutes), the load will be switched over from DG set to primary power and the generator shall be automatically stopped and be enabled for another future start-up request.

1.3.17 Remote and Local Monitoring

The DG set shall be capable of being monitored from remote as well as local.

1.3.17.1 Visual Annunciation

The following minimum visual annunciation shall be provided for DG set shut down due to:

- (i) Low fuel level
- (ii) Engine failed to start (failed to start in 60 sec. after receiving the first start impulse)

1.3.17.2 Remote Monitoring

The above parameters shall also be monitored remotely through telecom equipment NMS or any other independent remote monitoring arrangement. Suitable potential free dry contacts (NO) for this purpose shall be provided by the Contractor. The contractor shall do all the required wiring for such purpose.

1.3.18 General Requirements

The DG sets shall be generally installed at outdoor positions near to the shelter locations. The DG sets shall be installed either on ground near to Shelter installed at ground or on rooftop near to shelter installed at roof top. However, in some cases, the DG sets may be installed on ground and shall be connected to shelter installed on rooftop. The exact requirement shall be finalised during detail engineering based on actual site conditions.

1.3.18.1 Mounting and Installation

The generator set shall be skid mounted using anti vibration pads. At some locations, DG set may be installed on the rooftop. The required RCC floor/ PCC pedestals shall be provided by the Contractor.

1.3.18.2 Earthing

The Contractor shall suitably connect the DG sets with the integrated earthing system being provided by the Contractor under this package. The neutral of alternator shall be earthed separately.

1.3.18.3 Trenching

The Contractor shall prepare necessary cable routes for installing cables and earthing system from DG set to the shelter and earthing pits. The cables shall always be installed inside the GI pipes of suitable size embedded properly with PCC finish. In case the DG set is installed on ground and the shelter is installed at roof top, the necessary cable trenching/ GI pipe shall be provided from DG set to the building ground from where the cables shall be installed in the wall of the building. The cable trays with proper cover and supports shall be provided from bottom of the trench at the ground near the building up to the shelter installed at the roof top. The Contractor shall submit the detail drawings for the same for Employer's approval.

1.3.19 Operating Environment

The generator sets shall operate within the following ambient environmental requirements:

- (a) Operating temperature range: +2°C to +50°C
- (b) Maximum relative humidity at 23°C of 95% (non-condensing)
- (c) In non-filtered air containing a high proportion of dust
- (d) In a corrosive atmosphere (at high humidity) (e) At altitudes of up to 500 metres above sea level
- (f) The equipment must withstand mechanical vibrations as defined in the IEC 68-2-6 test requirements.

1.3.20 Cables and ACDBs

All cables of required size and ratings for proper functioning of the DG set including all accessories shall be supplied, installed and terminated by the Contractor.

1.3.20.1 AC Distribution Boards

The contractor shall provide AC Distribution Boards associated with each system. The AC distribution boards shall distribute power to the equipment and provide protection against failures on feeder circuits.

Generally, ACDBs shall be part of Power Interface unit (PIU), however, at few locations, Standalone ACDB shall be required where PIU is not required. ACDBs shall be wall mounted enclosure/panel as finalized during detailed engineering. They shall have indicating lamps and voltmeter to indicate three phase voltage on the bus.

The MCCB and sub-assemblies shall be easily replaceable and maintainable. The MCCBs of requisite ratings must conform to IEC-60947-2 and IS 13947-2/IEC 60947-2. All MCCBs shall provide over-current, short circuit protection and coordinate with associated breakers in upstream & downstream such that faults are cleared reliably with discrimination.

The contractor shall extend safety earth connections from Input ACDB panel & Output ACDB panel to nearest earthing system being provided under this contract.

1.3.21 Testing of DG sets

1.3.21.1 Type Test

The Contractor shall submit the earlier carried type test reports for the engines, Alternator & enclosure of the offered DG sets for the highest rating of offered DG set as per the latest relevant IS standards or equivalent International standard for Employer's approval. The type tests on Alternators shall be carried out as per Table 1.10(a) as given below.

1.3.21.2 Factory Acceptance Test

A complete DG set shall be assembled and installed at factory as being envisaged at site and shall be run to check proper installation and assembly of all items of the DG set. It shall demonstrate all specified design features and functional requirements as per specifications, for adopting the same at sites.

Manufacturer's internal test reports of Alternators for each DG set shall be submitted during FAT.

Table-1.10(a)
List of Tests for DG
Set

	Test	Type Test	Factory Acceptance Test	Site Acceptance Test
A. ALTERNATOR				
	Measurement of resistance	√		
	Regulation test	√	√	√
	Measurement of open circuit characteristics	√		
	Measurement of short circuit characteristics	√		
	Efficiency test	√		
	Temperature rise test	√		
	Occasional excess current test	√		
	Over speed test	√		
	Insulation resistance (both before & after high voltage	√		

	Test	Type Test	Factory Acceptance Test	Site Acceptance Test
	High Voltage test	√		
	Determination of deviation of voltage waveform sinusoidal	√		
	Note : All the above tests as per IS: 2 or equivalent international			
	B. DG Set (including Alternator)			
	Noise and vibration test	For all		√
	Load Test	Type tests	√	√ (Note)
	Functional tests on control panel, starting provision AVR and speed governor		√	√
	Note: SNo. 1 above: As per standard IS 12065/12075 or equivalent			
	1) During FAT, Load test shall be conducted on each rating of DG sets before dispatch to site as follows:			
	a) No load test for 15 minutes			
	b) 100% Load test for 8 hrs			
	c) 110% load test for 1 hr			
	2) During SAT, 6 hours load test shall be carried out with existing load.			
	3) The Oil consumption, governing, noise and vibration shall be recorded during the			
	---End of Table---			

1.3.21.3 Site Acceptance Test

After successful installation of the DG set, Site Acceptance Testing for each DG set shall be carried out at respective site. The total installed system in power up condition shall be tested for the specified functional requirements. The minimum requirements for SAT are given in Table 1.10(a) above. The timer setting for automatic DG set starting after normal power supply failure and for automatic shut off after restoration of normal supply shall be done at each site based on the actual site conditions. The detailed SAT procedure shall be submitted by the Contractor for Employer's approval.

1.3.22 Marking

The following information shall be provided on each DG sets:

- g. POWERGRID and its logo
- h. DG Set location name
- i. Identification no.
- j. Year of Manufacture
- k. DG set dimension
- l. DG set weight
- m. KVA rating, HP Rating
- n. Voltage, Per phase current

1.3.23 Tool Kit

One set of following tools of Taparia or other reputed make shall be supplied with each DG set;

Tool kit			
SNo.	Item Description	Unit	Qty
1	Digital Multimeter	No.	1
2	Cutter	No.	1
3	Pliers	No.	1
4	Nose Pliers	No.	1
5	D Spanner set (All sizes from 6 mm to 22 mm)	Set	1
6	Ring Spanner set (All sizes from 6 mm to 22 mm)	Set	1
7	Cable Cutter	No.	1
8	Hammer – 250 gm with handle	No.	1
9	Hack Saw	No.	1
10	Wire Stripper	No.	1
11	Screw Driver Set (-) type (6 Nos. of different sizes)	Set	1
12	Screw Driver Set (x) type (6 Nos. of different sizes)	Set	1
13	Tool Box (To accommodate all the above specified tools)	No	1
--End of Table--			

1.4 Requirement of Integrated Power Management System (IPMS)

Integrated Power management system (IPMS) shall be consist of Micro controller based true RMS Static Voltage Regulator (SVR), SMPS based DCPS Charger and AMF panel for DG control, etc. in the single unit to ensure the regulated supply to Air-Conditioners and DC supply to Telecom equipment and manage all the components automatically to maximize the utilization of the site resources with maintaining the site up time.

Integrated solution shall be designed for the energy sources from Grid, Battery and Diesel Generator (DG). The Controller of IPMS has wide range of battery charging current limit and shall be suitable for both Li-ion battery and VRLA battery charging. Battery should be charged with a higher current if Grid is available and limit the charging current if the site is on DG so as to protect the DG getting over loaded.

The IPMS shall be installed indoor or outdoor. The ingress protection for indoor & outdoor cabinet shall be minimum IP-20 and IP-55 respectively.

The IPMS in all the locations may be installed in an uncontrolled atmosphere and the ambient temperature may vary from min 0°C to 50°C, and maximum humidity of 95% (non-condensing). The IPMS will operate without any degradation of performance throughout range of the ambient condition so specified.

The SMPS based DCPS Charger shall be designed for ultimate capacity in the offered IPMS. The rating of SVR shall be as specified in the BOQ. AMF Panel and phase selector along with Distribution/Switching/ Alarm unit, contactor/fuse/ MCBs/wiring etc. shall be provided for the ultimate capacity. For DCPS, bus-bar should be sized for ultimate capacity, however, wiring, circuit breaker, fuse etc for Load and battery path shall be kept minimum 70% of ultimate capacity.

The IPMS has also provision to integrate external Single Phase/Three phase DCPS (up to 300A rating) supplied under this contract or existing available at site as redundancy of DC supply. At site all input AC source (EB/DG) connection will be terminated in IPMS. In case of failure/Shutdown of IPMS, AC mains (EB/DG) supply to external DCPS should not be interrupted.

The IPMS shall have an operating life of not less than 15 year.

1.4.1 Technical Experience

The IPMS shall be offered from a Manufacturer who has been manufacturing IPMS units for the last two (2) years and at least 10 nos. of IPMS units manufactured by such manufacturer should have in satisfactory operation for at least one (1) year as on the originally scheduled date of bid opening.

The Bidder shall furnish the details/document in support of above Technical Experience of manufacturer along with bid.

1.4.2 System Configuration

IPMS unit shall consist of following subsystems integrated in a single cabinet suitable for indoor and outdoor installations.

- i. SMPS based DCPS Charger
- ii. Static Voltage Stabilizer (three to one)
- iii. Main controller modules with inbuilt SNMP iv.
AMF Panel and DG control and protection system v.
Healthy phase selector
- vi. Lighting & Surge Protection
- vii. Smoke and fire detector
- viii. High temperature sensor device
- ix. Input cabling and AC & DC termination

1.4.2.1 SMPS based DCPS

SMPS based rectifier is intended to be used in Auto Float-cum-Charge mode as a regulated DC Power source in the IPMS. The system employs Switched Mode Rectifier (FR/FC) in a modular configuration for flexible provision of DC power. The contractor shall provide minimum two nos of rectifier modules to achieve ultimate capacity

Description	Specification
Input MCB	For Individual Modules of suitable rating.
Output	-42 to -57V
Low Voltage Disconnection Provision	Provision for disconnection of Non-Priority load in case of low battery voltage
Current Limit in Battery Path	Required. Should be settable through Controller.
Short Circuit Protection	Required
Output Voltage Measurement	Required

Output Current Measurement	Required
Battery Current Measurement	Required
Battery Temp Measurement	Required
Battery Temp Compensation	Required
Float/ Equalize Mode	Required
Battery Test Function	Required
Charge Equalization	Required (settable)
Battery health monitor and charging Current limit.	Required (settable)
Energy Efficiency Mode for Rectifier modules by switching ON / OFF rectifier modules automatically depending upon load.	Required.
Efficiency (25% to 100 % load)	Not less than 90%

1.4.2.2 Static Voltage Stabilizer (three to one)

SVR shall be used for air-conditioner, lighting and other AC loads. Technical requirements are given below:

Description	Specification
Control System	Micro Controller based static voltage regulator in sync with control system of IPMS
Rated input voltage range	240 - 480(L-L), AC
Rated Output Voltage	220 V± 10%, AC
Input Frequency Range	47-53 Hz
Total Harmonic Distortion (THD) % of Voltage/Current	<3%
efficiency on complete voltage range of 240 – 480 volts and at loading : 25 to 100 % load	>95%
Response Time	<10 millisecond

Protections:	
Voltage protection at incoming power input	Required
Voltage protection at SVR output	Required
Current protection at SVR output	SVR should have overload protection.
Additional Protection	i.SVR bypass under healthy phase condition ranging 195-245 with 15 v hysteresis.

1.4.2.3 Main controller modules

Micro controller	<p>IPMS system Shall have high end central 32 / 64 bit controller with Real time Operating System.</p> <p>Able to measure true RMS for all voltage & current, all the inputs to the measurement board shall be duly protected against surge IEC standard 61643-2009-1 including protection of all electronics cards and boards. The measurement circuit shall be rated at least twice of the maximum input range. All critical setting of IPMS controller shall be through authorised user having password protection.</p>
Time	Real time & date-programmable
Event logs	Last 500 events (minimum) for data analysis of complete IPMS data log for critical and recordable data including major alarms, energy data etc. The same shall be downloaded in excel format.
Local Configuration	Support Minimum Ethernet and USB interface

Energy measurement	<input type="checkbox"/> Shall be able to measure the DG energy (Cumulative KWH Hrs) <input type="checkbox"/> Shall be able to measure EB energy(Cumulative KWH Hrs) <input type="checkbox"/> Shall be able to measure Battery energy(Cumulative KWH Hrs) <input type="checkbox"/> Shall be able to store data of DC energy meter. <input type="checkbox"/> EB and DG cumulative running Hours and KWH for each calendar month/Daily to be recorded for last 2 month.
Smoke sensing and Actuation	The controller should ensure the complete input (mains and DG) shutdown of IPMS in case of fire/smoke alarm. The actuation shall be with latch-able and require physical hard reset and fault acknowledgment at IPMS.
IPMS Enclosure Temperature alarm management	Required (Settable)
LCD display of controller module	It shall display various site conditions like Mains ON, DG ON, Smoke/ Fire Alarm, Over Load, Charger MODULE fail, DG Fuel Low, DG fail to start, DG fail to stop, Alternator fail, LLOP, DG overload, Mains Fail, Site battery low, DG battery low, HCT/HWT, High Shelter temperature etc

In the IPMS, contractor shall integrate and extend the Potential Free Contacts for monitoring through NMS for following minimum alarms;

- (i) Mains Fail
- ii) Door Open
- iii) High Room Temperature
- iv) Battery Low
- v) Rectifier Fail
- vi) Fire and Smoke
- vii) DG Fail to Start
- viii) LLOP
- ix) Fuel Low
- x) DG ON LOAD
- xi) DG ON

- xii) HCT/HWT
- xiii) DG Over speed
- xiv) DG Fail to Stop

1.4.2.4 Automatic Mains Failure Panel (AMF Panel) and DG control and protection system

The IPMS unit shall support AMF panel for integration with DG set. The capacity of AMF panel shall be as per ultimate capacity of IPMS. The AMF shall start the DG set and transfer the AC load from normal source to diesel generator automatically in case of AC mains failure without any human intervention. Similarly on restoration of mains supply it shall be able to transfer the load to mains supply and switch off the DG automatically. Provision for a suitable delay shall be kept for starting of DG and changeover of load between DG & Mains. The AMF shall be site configurable for single and three phase generator options. Default arrangement shall be done considering single phase DG.

The IPMS shall be equipped with suitable instrumentation, interlock and protection arrangement, suitable annunciation and indications for proper start up, monitoring, control and safe operation of the DG set. There shall be a power based over load protection in the DG path. Load on DG shall be dynamically controlled to ensure optimum utilization of capacity

An option for selection of Auto / Manual Mode operation should be provided on the front panel of the IPMS. Operation (Start / Stop) of the DG set in manual mode should be available on the IPMS. In manual mode, AMF logic will be totally bypassed. However during manual mode, the DG protections will not be bypassed. A change over switch shall also be provided for total bypassing the AMF.

The AMF panel of IPMS shall be equipped with following minimum instrumentation:

- a. Microprocessor based controller with composite meter for digital display of;
 - i. AC mains Voltage & Generator Voltage
 - ii. Generator Current
 - iii. Output KW meter
 - iv. Output AC frequency meter
 - v. RPM indication/frequency measurement
 - vi. Over speed indication
 - vii. Engine hours indication (Cumulative)
- b. Mode selector switch for setting the panel on any one position such as Auto/ manual/ Test. The operation of the DG set shall be possible in any of the modes
- c. Engine ON/OFF switch (Push button type)
- d. ON delay timer for load change over.
- e. ON delay timer for engine shut off.
- f. LED to indicate 'Mains ON', 'Load on Mains', 'DG Running', 'Load on DG', 'Battery charger ON'
- g. LED indication alarms for

- i.Low lubricating oil pressure
- ii.High water temperature (for water cooled DG)
- iii.Start failure
- iv.DG over load
- h.Suitable DG battery charger complete with voltage regulator, on-off switch, digital voltmeter and ammeter for charging the DG battery from 48VDC Operated.
- i.MCCB of suitable rating
- j.Contactors of suitable ratings for DG set and AC mains.
- k.Under voltage relay for Mains.
- l. Any other switch, instrument, relay or contactor etc. essential for smooth and trouble free functioning of DG set with AMF panel. (To be specified by the bidder with complete detail of the item).

Standard colours codes and numbered ferrules shall be used for wiring the AMF panel. Sensing and control relays shall be of continuous duty, industrial control grade type. The transfer breaker shall be rated for continuous duty. The breaker shall be interlocked to ensure non-paralleling SEB power supply and DG supply.

Following automatic protection system for DG set shall also be integrated in the control panel of IPMS;

- Low lubricating oil pressure shut down.
- High coolant (water) temperature shut down.
- Engine over speed shut down.
- Over load shut down.
- Short Circuit shut down.
- Over Voltage shut down /Alternator Fail
- Low Fuel Level /Alternator Fail
- Emergency Stop

1.4.2.5 Healthy Phase selector

- IPMS system should have Healthy Phase selectors for SVR Section. All Input AC source (EB/DG) connection will be terminated in IPMS, However, appropriate termination shall also be provided to external power plant up to 300A (Single phase/Three phase) through the IPMS . IPMS shall automatically changeover power supply to External DCPS as per availability.
- IPMS system should work automatically on 3 phases, 2 phases and Single phase with neutral, in the sequence of 3/2/1 phase as per availability.

1.4.2.6 Lighting & Surge Protection

The IPMS shall be equipped with lightning and surge protection devices to provide protection to all the equipment being connected and integrated against incoming lightning and low voltage surges.

The protection system for both the above stages shall be reusable after clearance of surge. In case of fault, provision for manually bypassing the protection system should be available to ensure the operation without protection system. The manufacturer shall give complete details of the arrangement provided for the purpose during detail engineering.

Class B Protection:

- KEMA/VDE/UL/CE/TUV certified class 1/Type 1(Class B) pluggable protection devices, using encapsulated metal spark gaps, having safe and fire proof operation as per IEC 61643-1:2005 or EN 61643-11:2002+A11 :2007 test standards for discharge of direct lightning strikes and also during sustained high voltage. The device should have mechanical visual indication indicating the health of SPD.

Between Requirement

R, Y, B & N $I_{imp} \geq 25 \text{ kA}$, 10/350 μS for each
phase N & PE $I_{imp} \geq 100 \text{ kA}$, 10/350 μS
 I_{imp} = Value of Lightning Impulse Current

- Shall be capable to coordinate directly with Class II/Type 2 (Class-C) arrester.
- During neutral shift or abnormally high voltage in neutral, device should not catch fire.
- Response Time: $\leq 100 \text{ ns}$ (L-N & N-PE)
- Short circuit withstand and follow up
- current extinguishing capacity without back up fuse (I_{sc}): 25 KA rms
- Operating Voltage Range: 120-300 VAC
- Technology: Single Spark Gap / Single Block MOV /
Single Spark gap & Single MOV
- Indication: Required

Class C Protection:

Between Requirement

R, Y, B & N $I_n \geq 10 \text{ kA}$, 8/20 μS for each
phase
N & PE $I_n \geq 20 \text{ kA}$, 8/20 μS
 I_n = Value of Nominal Discharge Current

- Class C protections needs to be installed at the distribution bus bar. It should be installed to take of protection at both EB and DG paths.
- KEMA/VDE/UL/CE/TUV certified, pluggable with visual indication showing the health of SPD.
- During neutral shift or abnormally high voltage in neutral, device should not catch fire.

Class D Protection:

- Class D surge protection at Rectifier module level

1.4.2.7 Smoke and fire detector

The contractor shall provide smoke and fire detector device inside cabinet for avoiding fire and any damages inside IPMS.

Smoke detector	Photoelectric type installed in IPMS cabinet only for enclosure fire
Operating voltage	48 VDC
Compliance	with BS 5839 Part – 4

1.4.2.8 High temperature sensor device

The IPMS should have high temperature sensor device inside cabinet for thermal Management.

1.4.2.9 Input cabling and AC & DC termination

System Input cabling should be 3 Phase 4 wire System with earth ensuring appropriate cable rating internally considering safety factors, bolted termination for external cable correction, working space and input cable armoured earthing.

Depending upon the system requirements and manufacturer's design, All IPMS racks shall be provided with a distribution/switching/Control and Alarm unit (arrangement) for the ultimate system capacity.

The unit shall comprise of the following:

- i. Termination for the batteries (VRLA/lithium)
- ii. Termination for the load.
- iii. Interconnecting arrangement for power equipment.
- iv. Battery switching Arrangement (Connection to/isolation from system)
- v. Termination for AC input to the IPMS.
- vi. Termination for AC and DC to modules.
- vii. Termination for DG set.
- viii. Termination for external DCPS
- ix. Circuit breakers/fuses etc.

1.4.2.9.1 ACDB for load distribution

There shall be AC distribution panel for termination of the load. The Air conditioners, lighting system, etc. shall be connected to this AC distribution panel through suitable MCBs. The ratings of the MCBs shall be selected to provide safe and continuous operation of the IPMS system.

ACDB

2x63A, 2x32A, 2x16A, 2x10A, 2x6A rating MCBs

1.4.2.9.2 DCDB for load distribution

DC distribution shall be provided with adequate number of feeders and appropriate MCBs of different rating for termination of the load in the suitable DCDB. The DCDB shall be wall mounted installed inside shelter and make arrangement for connection of DCDB with DC bus bar of IPMS. There shall be separate DCDB for critical and non-critical load. In the outdoor IPMS there shall be provision to install DCDB inside outdoor cabinet.

For indoor IPMS (300A)

Feeders for critical load: 1x100A, 2x63A, 2x32A, 2x20A & 2x10A

MCB Feeders for non-critical load: 63A, 32A, 20A & 10A MCB

For outdoor IPMS, the requirements of MCB of different ratings are mentioned in the BOQ.

1.4.3 Constructional Features of Enclosure

Only a single enclosure shall accommodate all the systems that include phase selector, surge protection devices, static voltage stabilizer, AMF panel, SMPS based rectifier module, main controller, smoke and fire detector, digital displays and meters, wires and cables, associated sub systems etc. The dimensions of the enclosure shall be such that it shall accommodate all components inside the cabinet and suitable for installation at inside & outside area of Telecom shelter. The outdoor & indoor cabinet shall meet IP-55 & IP-20 standard respectively and minimum height of cabinet should be 2200mm.

The enclosure (rack) shall be freestanding type of design and shall have sufficient structural strength to withstand the ultimate mechanical load capacity without any deformity. All the component and materials used in IPMS must be non-combustible and fire retardant.

For indoor IPMS, proper thermal engineering of hardware design shall be done by the Contractor so as to ensure the uninterrupted use of the equipment. Forced cooling is permitted (DC Fans are permitted in the rack or FR/FC module). If cooling is provided at rack level it shall be provided with additional fan with facility for manual switch over. Proper filtering shall be provided to control dust ingress. There shall be an arrangement for automatic Switching-OFF of fans during AC input failure. If required individual modules may be separated by air baffle to provide effective convection. The contractor shall also ensure that the failure of fan does not cause any fire hazards. The failure of any of the fans shall draw immediate attention of the maintenance staff.

For outdoor IPMS, Temperature sensing based forced Air Cooling shall be provided to keep temperature difference of 10 degree (Ambient Temperature-10 degree) with auto fan cut off to meet temperature inside IPMS and ensuring minimum power utilization by cooling fans. Common alarm for high IPMS temperature needs to be provided with auto shutdown protection of IPMS crossing temperature beyond threshold limits. Minimum one fan redundancy shall be considered in design of thermal management. Auto fan shutdown as safety should be provided in case of back door open.

IPMS shall have enough space for heat dissipation, air circulation and ease of service under prevailing ground conditions and maintenance criteria.

1.4.3.1 Components

The component parts of the equipment shall be of professional grade from reputed manufacturer to ensure continuous and safe operation of the equipment including its sub systems. The component shall conform to relevant IEC/IS standards and Complete IPMS unit shall ensure compliance to safety as per IEC-60950 or any other international standard.

1.4.4 Make

All accessories items likes cable, MCB, PVC etc should be relevant latest IS standard.

1.4.5 Earthing

The equipment shall be properly earthed by connecting it to existing available earthing system.

1.4.6 MTBF

The mean time between the faults of the IPMS and its subsystems shall be more than 70,000 hrs.

1.4.7 Testing

Type Testing

IPMS shall conform to EMI/EMC requirements as per IEC-870-2-1 standards. It shall also conform the Environmental requirements as per the TEC Standard for Environmental testing i.e. SD: QM-333 Mar 2010 (with amendments, if any) in category B2 and also comply IS-8448 standard for transformer of IPMS.

Electrical and mechanical safety and Performance test shall also be carried out on IPMS as per specification. The Contractor can also submit the earlier carried out type test reports on the offered system for above tests.

Factory Acceptance Testing

The Contractor shall submit the detailed format of factory acceptance testing plan for IPMS unit incorporating various tests for testing of all its systems and sub systems and get it approved from the Employer. The FAT shall be conducted on the offered IPMS units as per approved FAT tests and procedure.

Site Acceptance Test

After successful installation, the site acceptance testing for IPMS unit including its subsystems shall be carried out by the Contractor for each site demonstrating all its functions properly. The detailed SAT procedure shall be submitted by the Contractor for Employer's approval.

1.5 DC Power Supply system

In order to provide reliable power supply to communication equipment at various locations, 48 V DC Power Supply (DCPS) system is to be provided as a part of this project. This section describes the technical requirement of DC power supply & associated Battery.

The DC Power Supply system shall be capable of meeting the load requirements for various Telecom equipments. The rating of offered SMPS modules shall meet Employer's requirements of DCPS system as stipulated in the BoQ.

The DC Power supply system shall have a single DCPS system as per conceptual configuration diagram given in Fig.3-1, shall be supplied.

Surge protection devices shall be installed in the DCPS panel to provide adequate protection against current and voltage transients introduced on input mains AC due to load switching and low energy lightning surges. These protection devices shall be in compliance with IEC 61312, IEC 61024 and VDE 0100-534 for following surges:

It shall be provided with Class 'B' & 'C' type surge protection device. The device must be provided with Class B type lightning current arrester (Switching Type) with a discharge current capacity of at least 50 kA, 10/350 μ s, and Class C type surge arrester (linear device) as per IEC 61643-1. The blind spots shall be avoided in accordance to IEC 61312. The Class 'C' surge protection device should be pluggable type, equipped with features of thermal disconnection, & health indication and potential free contacts for surge arrestors connected between phase & neutral.

The surge protection device shall comply to IEC 61643.

1.5.1 General Technical Requirements for SMPS based DC power supply units

SMPS based DC power supply system is to be used in Auto Float-cum-Boost Charge mode as a regulated DC Power source. DCPS system is to be installed indoors and shall be provided with IP21 panels. The System shall consist of the following:

SMPS modules

- a) Controller module to control and monitor all DCPS modules.

The Panel, Distribution/Switching arrangement shall be provided for the ultimate system capacity. Ultimate System capacity is defined as 150% of the present capacity specified. The ultimate capacity is over and above the requirement of redundancy wherever specified. All factory wiring for the panel shall be for the ultimate capacity so that only plugging-in of SMPS module shall enhance the DC power output.

The size of fuses, MCBs, switch, bus etc shall be suitable for the ultimate capacity.

The SMPS modules of DCPS system shall be suitable for operation from single phase A.C. mains/DG set supply. However, the input AC mains supply to DCPS system shall be 3-phase, 4 wire which shall be evenly distributed among all the offered SMPS modules.

1.5.1.1 Operational/Component Requirements

The basic modules shall operate at specified ratings and conform to requirements stipulated in this specification. The DCPS system shall meet requirement of the latest TEC specification / IEC/BS for other parameters as applicable.

1.5.1.2 Wiring

All insulated conductors except those within the confines of a printed circuit board assembly shall be of the rating enough to withstand the maximum current and voltage during fault and overload. All insulated conductors/cables used shall conform to IS 1554 or equivalent international standard.

1.5.1.3 Bus Bars

High conductivity Cu bus bar shall be provided and shall be sized to take care of the current of ultimate DCPS system capacity for which it is designed. However, it shall not be less than 25mm X 5mm.

1.5.1.4 Earthing

Two earth terminals shall be provided in the frame of the system. The Contractor shall connect these earth terminals to the earth bus. All modules and devices shall be connected to these earth terminals. The hinged door, if provided shall be connected to the panel with braided Cu at two points at least.

1.5.1.5 Marking and Labelling of Cables

The Contractor shall propose a scheme for marking and labelling the inter panel cables by Halogen & Silicon free labels of polyamide ensuring scratch proof labelling with the use of solvent free ink & latest UV Technology making it environment friendly printing with a WIPE RESISTANCE according to DIN EN 61010-1/VDE 0411-1 and get it approved from the Employer. A cabling diagram, screen printed or any other better arrangement ensuring better life expectancy shall be placed in the inside of the front door or any other convenient place for ready reference of the maintenance staff.

1.5.1.6 System and Panel Configuration

The mechanical and electrical requirements of the Panel are described as below:

1.5.1.7 System Configuration

The SMPS modules shall be accommodated in panels. The system shall employ a modular configuration to provide flexibility, keeping in view the future load requirements of DC Power. The system shall be configured for ultimate capacity as brought out in Section 3.1. The Control, Monitoring, Alarm arrangement and DC & AC distribution shall be provided suitably in the panel.

The SMPS modules shall be provided as per the load requirement stipulated in the Appendix, BOQ. The DCPS system shall comprise of N+2 Modules. In case of DCPS system having N=1, the SMPS shall comprise of N+1 modules. Here N refers to number of SMPS modules to meet the load requirements specified in the Appendix, BOQ and battery charging current. The current rating of each module shall be considered as output current of the SMPS module at nominal voltage (48V).

Total current = load current + battery charging current

Where, battery charging current is equal to the 20 % AH of the battery supplied.

$$N = \frac{\text{Total Current}}{\text{Current rating of each SMPS module at 48 V}}$$

The Distribution/switching/Alarm unit shall be provided for the ultimate system capacity. All AC, DC or control/alarm cabling/wiring shall be pre-wired for the ultimate capacity so that mere plugging-in of SMPS module shall add to the DC power output.

1.5.1.8 Constructional Features of Panel

For the enclosures/panel, the front door (if provided) shall not be wider than 80 cm and rear door may be of hinged or removable type with locking as per standard design of the manufacturer. Keyed locking is required with identical keys for all enclosures. The enclosures shall not exceed 220 cm in height. The thickness of the structural frames and load bearing members shall be minimum 2.0 mm and for others shall be minimum 1.6 mm. The panels/boards shall be equipped with necessary cable gland plates. The degree of protection of DCPS enclosures shall preferably be IP21.

Conductors in multi conductor cables shall be individually colour coded, and numbered at both ends by Halogen & Silicon free labels of polyamide ensuring scratch proof labelling with the use of solvent free ink & latest UV Technology making it environment friendly printing with a WIPE RESISTANCE according to DIN EN 61010-1/VDE 0411-1 within enclosures.

Each panel shall be supplied with 240 VAC, 50Hz single-phase sockets with switch and lighting lamp for panel illumination.

The Panel shall be designed to allow cooling preferably by natural convection. The Contractor shall submit detail design of proposed Panel/enclosure and heat dissipation calculations during detailed engineering. Forced cooling is permitted (DC Fans are permitted in the Panel or SMPS module) for equipment mounted indoors (buildings/rooms/shelters). Proper filtering shall be provided to control dust ingress. There shall be an arrangement for automatic Switching-OFF of fans during AC input failure.

1.5.1.9 Electrical Requirements:

AC input supply: The nominal input frequency is 50 Hz, which may vary from 47.5-52.5Hz. The input voltage shall be as mentioned below:

Field Site Application – Three phase/4Wire (Nominal 415/240 V): 415 + 10 % - 15%. However, at site the voltage may vary from 160V to 300V (Ph-N). An Auto-Mains Changeover unit shall be provided for each field site DC power supply system. The Auto-Mains Changeover unit shall accept input from two AC sources and extend any one of the available healthy sources to the DC Power supply system.

The suitable HVD (High Voltage Disconnecter) Protection shall be provided at input of each DCPS system. This HVD protection shall protect the SMPS modules of DCPS system against the sustained over voltage at the input.

A tolerance of $\pm 5V$ may be acceptable for protection & alarm operation.

1.5.1.10 DC output Characteristics of Modules

The module shall be capable of operating in “Auto Float-cum-Boost Charge” mode depending on the condition of the battery sets being sensed by the Control unit.

- (a) The float voltage shall be continuously adjustable & pre-settable at any value in the range of -48 to $-56V$ or as per battery manufacturer recommendations either at the module or may be set from the common controller configuration. Further, the prescribed float voltage setting shall be based on recommendations of the battery supplier.
- (b) In Boost charge mode, DCPS shall supply battery & equipment current till terminal voltage reaches set value, as recommended by the battery supplier & shall change over to constant voltage mode
- (c) The DC output voltage variation shall not be more than 2% for load variation from 25% load to full load.

1.5.1.11 Current Limiting (Voltage Droop)

The current limiting (Voltage Droop) shall be provided in DCPS SMPS modules in float and boost charge modes of operation. The float/boost charge current limiting shall be continuously adjustable between 50 to 100% of rated output current for output voltage range of -44.4 volts to -56 Volts or as per manufacturer’s specified catalogue.

The float and boost charge current limit adjustment shall be provided in the DCPS system. The SMPS modules shall be fully protected against short circuit. It shall be ensured that short circuit does not lead to any fire hazard.

1.5.1.12 Soft/Slow Start Feature

Soft/Slow start circuitry shall be employed such that SMPS module input current and output voltage shall reach their nominal value within 10 seconds.

The maximum instantaneous current during start up shall not exceed the peak value of the rectifier input current at full load at the lowest input voltage specified.

1.5.1.13 Voltage Overshoot/Undershoot

The requirements of (a) to (c) given below shall be achieved without a battery connected to the output of SMPS modules.

- (a) The SMPS modules shall be designed to minimize DC output voltage Overshoot/Undershoot such that when they are switched on the DC output voltage shall be limited to $\pm 5\%$ of the set voltage & return to their steady state within 20 ms for load variation of 25% to 100%.
- (b) The DC output voltage overshoot for a step change in AC mains as specified in clause 4.3.12 Electrical Requirements shall not cause shut down of SMPS module and the

voltage overshoot shall be limited to $\pm 5\%$ of its set voltage and return to steady state within 20ms.

- (c) The modules shall be designed such that a step load change of 25 to 100% and vice versa shall not result in DC output voltage Overshoot/Undershoot of not more than 5% and return to steady state value within 10 ms without resulting the unit to trip.

1.5.1.14 Electrical Noise

The Rectifier (SMPS) Modules shall be provided with suitable filter at output with discharge arrangements on shut down of the modules. The Psophometric Noise (e.m.f weighted at 800Hz) with battery connected across the output should be within 2 mV at full load at nominal input AC supply. For test purposes, this shall be taken as equivalent to 4mV when the battery is not connected and in accordance to ITU-T Rec. O.41.

Voltage at the output of the Rectifier (SMPS) module, without battery connected, shall not exceed 300 mV at the switching frequency measured by an Oscilloscope of 50/60 MHz bandwidth (Typical).

1.5.1.15 Parallel Operation

SMPS modules shall be suitable for operating in parallel with one or more modules of similar type, make and rating, other output conditions remaining within specified limits.

The current sharing shall be within $\pm 10\%$ of the average current per rectifier module individual capacity of each rectifier module in the system (mounted in the same or different Panels) when loaded between 50 to 100% of its rated capacity for all other working conditions.

1.5.1.16 Protection

The SMPS module, which has failed (for any reason) shall be automatically isolated from the rest of the modules and an alarm shall be initiated for the failure.

1.5.1.17 DC Over voltage protection

DCPS shall be fitted with an internal over voltage protection circuit.

In case output DC voltage exceeds $-57V$ or as per the recommendations of the manufacturer of batteries, the over voltage protection circuit shall operate & shut off the faulty module. A tolerance of $\pm 0.25V$ is permitted in this case.

Shutting off of faulty SMPS module shall not affect the operation of other SMPS modules operating in the Panel. Operation of over voltage shut down shall be suitably indicated and extended monitoring/control unit.

The circuit design shall ensure protection against the discharge of the Battery through the SMPS module in any case. The over voltage protection circuit failure shall not cause any safety hazard.

1.5.1.18 Fuse/Circuit Breakers

Fuses or miniature circuit breakers (MCB) shall be provided for each SMPS module as follows:

- 1.Live AC input line
- 2.Control Circuit

All fuses/circuit breaker used shall be suitably fault rated.

1.5.1.19 AC Under/Over Voltage Protection

AC input Under/Over voltage protection shall be provided as per clause 3.1.11 for Electrical Requirements. The DC side of the SMPS should also be provided with surge protection device to protect the SMPS in case of transients being generated by the loads or due to induction in the DC line from the AC line running parallel together. The Surge protection device should be able to discharge a current of at least 10 kA of 8/20 μ s (Class 'C' surge arrestor), pluggable and should have indication to show its health to facilitate the replacement on fault condition.

1.5.1.20 Over Load/Short Circuit Protection

The SMPS shall be protected for Over load/Short circuit as per clause 3.1.13 Current Limiting (Voltage Droop).

1.5.1.21 Alarms and indicating lamps

Visual indications/display such as LEDs, LCDs or a combination of both shall be provided on each SMPS module for detection of SMPS module failure.

1.5.1.22 Termination

Suitable termination arrangements shall be provided in the panel for termination of inter cubicle cables from other equipment such as Employers ACDB, Telecom and other associated equipments and alarm cables.

1.5.1.23 DC Terminations

All terminations including through MCBs shall be through lock and screw type terminations. Load and batteries shall be connected to DCPS through appropriate MCBs. The isolation of any of the battery from the load shall create an alarm. DC distribution shall be provided with adequate no. of feeders with appropriate MCBs (6 Amp thru 32 Amp) for termination of the loads. Actual rating of the MCBs shall be finalized during the detail engineering. The no. of feeders shall be minimum 10 (ten) nos.

DC distribution may be done either on wall mounted panel or on the DCPS panel. The proper rated MCB shall be provided at the combined output of the SMPS modules (if not provided at each SMPS module). All the AC, DC and Control/alarm cabling shall be supplied with the Panel. All DC +ve and -ve leads shall be clearly marked. All conductors shall be properly rated to prevent excessive heating.

1.5.1.24 Earthing Cables

Earthing cables between equipment and grounding bus bars shall be minimum size 70 mm² stranded conductors copper/copper strip, rated at 300 volts. All hinged doors shall be earthed through flexible earthing braid. Signal and Safety earthing shall be provided separately.

1.5.1.25 Alarms

Following Visual indications/display such as LEDs, LCDs or a combination of both shall be provided to indicate:

Functional Indications for local monitoring:

- a) Mains available
- b) DCPS/SMPSs in Float charge Mode
- c) DCPS/SMPSs in Boost Charge Mode

Alarm Indication for local monitoring:

- a) Load Voltage High /Low
- b) DCPS module/SMPS fail
- c) Mains out of range
- d) System Over Load
- e) Mains "ON"/Battery Discharge
- f) Battery fail/isolated

All the protections/alarms shall be within tolerance of 0.25V in case of DC voltage, 1% in case of DC current and $\pm 5V$ for AC voltage

Alarm Indication for remote monitoring:

- a) Input AC mains supply fail alarm
- b) Battery low voltage (Pre cut off) alarm
- c) DCPS module fail

Potential free Contacts in two numbers for each of the above remote monitoring alarms (one for remote alarm interfaced through communication equipments and one redundant for local monitoring at suitable location) shall be provided. All these potential free contacts are to be wired and terminated at the suitable location for interfacing purpose.

1.5.1.26 Digital Meters/Display Unit

There shall be provision to monitor the following parameters through digital meters or digital display units:

- (a) Input AC voltage.
- (b) Out put DC voltage
- (c) Output DC current of charger
- (d) Battery current
- (e) Load current.

The Digital display of meters or LCD based display unit shall be with minimum 31/2 digital display of height 12mm and shall have accuracy 1.5% or better.

1.5.2 Cabling & Enclosure Requirements

The contractor shall supply, install and commission all power cables, control cables, network interface cables and associated hardware (lugs, glands, cable termination boxes etc.) as required for all equipment. The contractor shall be responsible for Cable laying and termination at both ends of the cable. The Contractor shall also be responsible for termination of feeder cables at contractor's equipment end including supply of suitable lugs, glands, terminal blocks & if necessary cable termination boxes etc. All cabling, wiring, and interconnections shall be installed in accordance with the following requirements.

1.5.2.1 Power Cables

All external power cables shall be stranded Aluminium conductor, armoured XLPE/PVC insulated and sheathed, 1100V grade as per IS-7098 Part-I/IS 1554 Part-I.

1.5.2.2 Enclosure/Panel Earthing

Each enclosure shall include suitable earth networks within the enclosure. Earth network shall be a copper bus bar, braid or cable inside enclosures.

The safety earth network shall terminate at two/more studs for connecting with the earthing grid. Safety earthing cables between equipment and enclosure grounding bus bars shall be minimum size 6 sq. mm, stranded copper conductors, rated at 300 volts. All hinged doors (if provided) shall be earthed through flexible earthing braid.

For all enclosures requiring AC input power, the green earthing wire from the AC input shall be wired to the safety earthing stud. The Contractor shall provide all required cabling between enclosures for earthing. The contractor shall connect safety and signal earths (as applicable) of each enclosure to the Employer provided nearest earth grid/earth riser through suitable 50X6 sq. mm. GI strips or suitably sized copper cable.

The signal earthing network shall terminate at a separate stud connection, isolated from safety ground. The stud connection shall be sized for an external earthing cable equipped with a suitable lug.

All earthing connections to equipment shall be made directly to each equipment chassis via earthing lug and star washer. Use of the enclosure frame, skins, or chassis mounting hardware for the earthing network is not acceptable.

1.5.3 Temperature Compensation for Battery

There shall be provision for monitoring the temperature of battery and consequent arrangement for Automatic temperature compensation of the SMPS output voltage to match the battery temperature dependent charge characteristics. The output voltage of the rectifier in Float/Charge operation shall decrease or increase at the rate of 72 mV (3mV/cell, 24 cell battery) per degree increase or decrease in temperature over the set voltage or as may be recommended by the VRLA Battery supplier. A tolerance of +/- 5mV may be acceptable over the specified rate of 72 mV/degree C. The output voltage shall decrease till the open circuit voltage of the battery is reached. The open circuit voltage range shall be settable between 2.1V/cell to 2.2V/cell. The increase in output voltage due to decrease in temperature has been taken care of by the tripping of the unit due to output voltage high (57V) protection. Failure of temperature compensation circuit including sensors shall create an alarm and shall not lead to abnormal change in output voltage. The nominal distance between the battery & DCPS system may be 20 metres. The Contractor shall provide the necessary sensor and cord for the purpose with DCPS system to sense the Battery temperature.

**FIG.: CONCEPTUAL CONFIGURATION OF DC POWER SUPPLY (DCPS) SYSTEM
(For Field Sites Locations)**

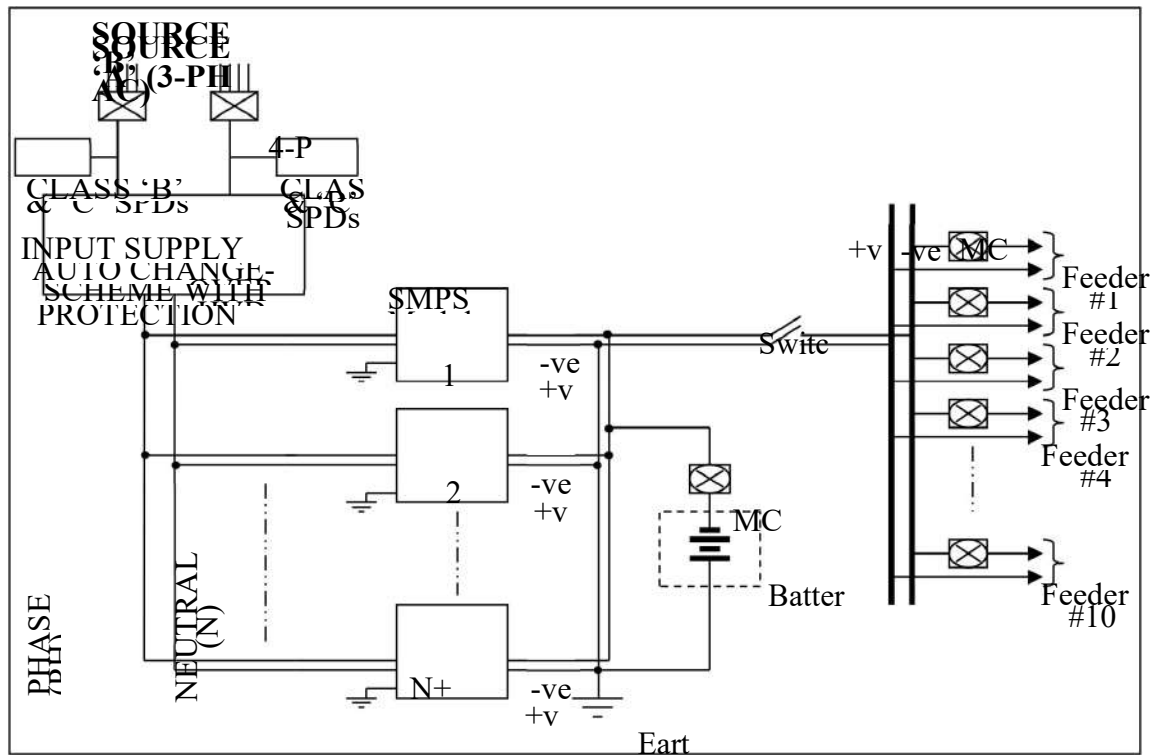

1.5.4 Battery Requirements

1.5.4.1 Valve Regulated Lead Acid (VRLA) maintenance free Battery

The contractor shall supply Valve Regulated Lead Acid (VRLA) maintenance free Battery. Each battery set shall have sufficient capacity to maintain output at full rated load as indicated in BOQ in Appendix. The battery shall be capable of being recharged to 90% State of Charge (SOC) from the fully discharged condition (1.75V/cell) within 10 hrs. In all cases, the battery is normally not allowed to discharge beyond 80% of rated capacity (80% DOD) at 10 hours rate of discharge.

The supplier, supplying the cells/batteries as per this document shall be responsible to replace/repair free of charge, the battery/cell becoming faulty, owing to defective workmanship or material as per the provisions of the bid document

1.5.4.2 Containers

The container material shall have chemical and electro-chemical compatibility and shall be acid resistant. The material shall meet all the requirements of VRLA batteries and be consistent with the life of battery. The container shall be fire retardant and shall have an Oxygen Index of at least 28%. The porosity of the container shall be such as not to allow any gases to escape except from the regulation valve. The tensile strength of the material of the container shall be such as to handle the internal cell pressure of the cells in the worst working condition. Cell shall not show any deformity or bulge on the sides under all working conditions. The container shall be capable of withstanding the rigours of transport, storage and handling. The containers shall be enclosed in a steel tray.

1.5.4.3 Pressure Regulation Valve

Each cell shall be provided with a pressure regulation valve. The valve shall be self re-sealable and flame retardant. The valve unit shall be such that it cannot be opened without a proper tool. The valve shall be capable to withstand the internal cell pressure specified by the manufacturer.

1.5.4.4 Flame Arrestors

Each cell shall be equipped with a Flame Arrestor to defuse the Hydrogen gas escaped during charge and discharge. Material of the flame arrestor shall not affect the performance of the cell.

1.5.4.5 Battery Bank Stand

All batteries shall be mounted in a suitable metallic stand/frame. The frame shall be properly painted with the acid resistant paint. The suitable insulation shall be provided between stand/frame and floor to avoid the grounding of the frame/stand.

1.5.4.6 Capacity Requirements

When the battery is discharged at 10 hour rate, it shall deliver 80% of C (rated capacity, corrected at 27°Celsius) before any of the cells in the battery bank reaches 1.85V/cell.

All the cells in a battery shall be designed for continuous float operation at the specified float voltage throughout the life. Float voltage of each cell in the string shall be within the average float voltage/cell +0.05V band.

The capacity (corrected at 27°Celsius) shall also not be less than C and not more than 120% of C before any cell in the battery bank reaches 1.75V/cell. The battery voltage shall not be less than the following values, when a fully charged battery is put to discharge at C/10 rate:

- (a) After Six minutes of discharge :
1.98V/cell
- (b) After Six hours of discharge :
1.92V/cell
- (c) After 8 hours of discharge :
1.85V/cell
- (d) After 10 hours of discharge :
1.75V/cell

Loss in capacity during storage at an average ambient temperature of 35° Celsius for a period of 6 months shall not be more than 60% and the cell/battery shall achieve 85% of its rated capacity within 3 charge/discharge cycles and full rated capacity within 5 cycles, after the storage period of 6 months. Voltage of each cell in the battery set shall be within +0.05V of the average voltage throughout the storage period. Ampere hour efficiency shall be better than 90% and watt hour efficiency shall be better than 80%.

1.5.4.7 Expected Battery Life

The battery shall be capable of giving more than 1200 charge/discharge cycles at 80% Depth of discharge (DOD) at an average temperature of 27° Celsius. DOD (Depth of Discharge) is defined as the ratio of the quantity of electricity (in Ampere-hour) removed from a cell or battery on discharge to its rated capacity. The battery sets shall have a minimum expected operational life of 5 years at normal operating conditions or 1200 charge/discharge cycles (whichever is early).

1.5.4.8 Routine Maintenance of Battery system

For routine maintenance of battery system, the contractor shall supply one set of following tools:

- a. Torque wrench.
- b. Tool for opening /closing of pressure regulation valve of battery.

1.5.4.9 Testing requirements

The Contractor shall submit type test reports for the battery for the same make, model & rating as offered as per the IEC 60896 or equivalent IS/EN/BS/TEC standards. In the event, the type test reports for exact rating is not available, the Contractor shall submit type test reports for higher rating Battery.

1.5.4.10 List of Type Tests

The type testing shall be conducted on the following equipment

- (a) DCPS
- (b) Battery System

1.5.4.10.1 Type testing of DCPS

The test reports for Immunity, Emission and safety must be in accordance with relevant IEC/CISPR standards shall be submitted. The Contractor shall submit the DCPS type test reports of earlier conducted tests on the same make, model, type & rating which shall include the following tests listed in Table A.

Table A Type Tests on	
1	Surge immunity (Level 4- as per IEC 61000-4-5)
2	Electrical Fast Transients/Burst (Level 4 – as per IEC 61000-4-4)
3	Electrostatic Discharge (Level 4 – as per IEC 61000-4-2)
4	Radiated Electromagnetic Field (Level 3 – as per IEC 61000-4-3)
5	Conducted disturbances induced by radio-frequency field (Level 3 – as per IEC 61000-4-6)
6	Damped oscillatory magnetic field (Level 3 – as per IEC 61000-4-10)
7	Voltage dips, short interruptions and voltage variations (Level 2 – as per IEC 61000-4-11)
8	Conducted Emission (Level - Class A, Group 1 as per IEC CISPR 11)
9	Radiated Emission (Level - Class A, Group 1 as per IEC CISPR 11)
10	Safety Tests (as per IEC 60950)

1.5.4.10.2 Testing Requirements of Battery

Table B
List of tests for VRLA battery

Sl. No.	Test	Type Test As per IEC	FAT	SAT
1.	Verification of marking - Visual observation - Dimensional inspection - Polarity checking	√	√	√
2.	Capacity test	√	√	√

3.	Suitability for floating battery operation	√		
4.	Endurance in discharge/charge cycles	√		
5.	Charge Retention	√		
6.	Short-circuit current and internal resistance	√		
7.	Stability against mechanical abuse of units during installation	√		

NOTE :
The batteries shall meet the general requirements as per IEC 60896 or equivalent.

1.5.4.11 Factory Acceptance Tests

1.5.4.11.1 FAT/SAT of DCPS

The factory/site tests to be carried out on DCPS system/module in the factory and site are listed respectively in Table C below.

Table C			
Lists of tests for FAT/SAT of DCPS			
S.No	Test	FAT	SAT
Tests on DCPS System			
1.	Mechanical & Visual Check Tests	√	√
2.	Insulation Test.	√	
3.	High Voltage Withstand Test	√	
4.	Switch On Test	√	√
5.	DCPS Low voltage & High voltage limits check Test	√	√
6.	Pre-alarm test for Battery Voltage Low	√	√
7.	Battery Low Voltage Disconnect Level Test	√	√
8.	AC Input Low and High voltage limits	√	
9.	Rectifier Fail Alarm Test	√	√
10.	Voltage Regulation Test	√	
11.	Current Sharing Test	√	
12.	Total Output Power Test	√	√
13.	Hot Plug In Test (if applicable)	√	√
14.	Calibration & Parameter settings	√	√
15.	Automatic Float cum Boost Charge Mode Change Over Test	√	√
16.	Battery Path Current Limiting Test	√	√
17.	Battery Charging and full load Current Test	√	√

Table C
Lists of tests for FAT/SAT of
DCPS

S.No	Test	FAT	SAT
18.	Total Harmonic distortion Test	√	
19.	Burn in Test at 50 ° C (for 8 hrs duration)	√	
Tests on SMPS module			
20	Mechanical & Visual Check Test	√	
21	Module-On Test	√	
22	Input low/high voltage cut-off test	√	
23	Voltage Drop Test	√	
24	Voltage Regulation Test	√	
25	Power Output & Current Limit Test	√	
26	DC High Voltage Test	√	
27	O/P Voltage Ripple Test	√	
28	Psophometric Noise Test	√	
29	Efficiency Test	√	
30	Power Factor	√	
31.	Input Current Limit	√	
32.	Input AC Frequency Range Test	√	
33.	Rectifier Dynamic Response	√	
34.	Output Short Circuit Test	√	
35.	Hold up Time Test	√	